

# AMIAD WATER SYSTEMS

---

## TEQUATIC™ PLUS F-150 FILTER, C-SERIES SKID INSTALLATION, OPERATION, AND MAINTENANCE MANUAL

---

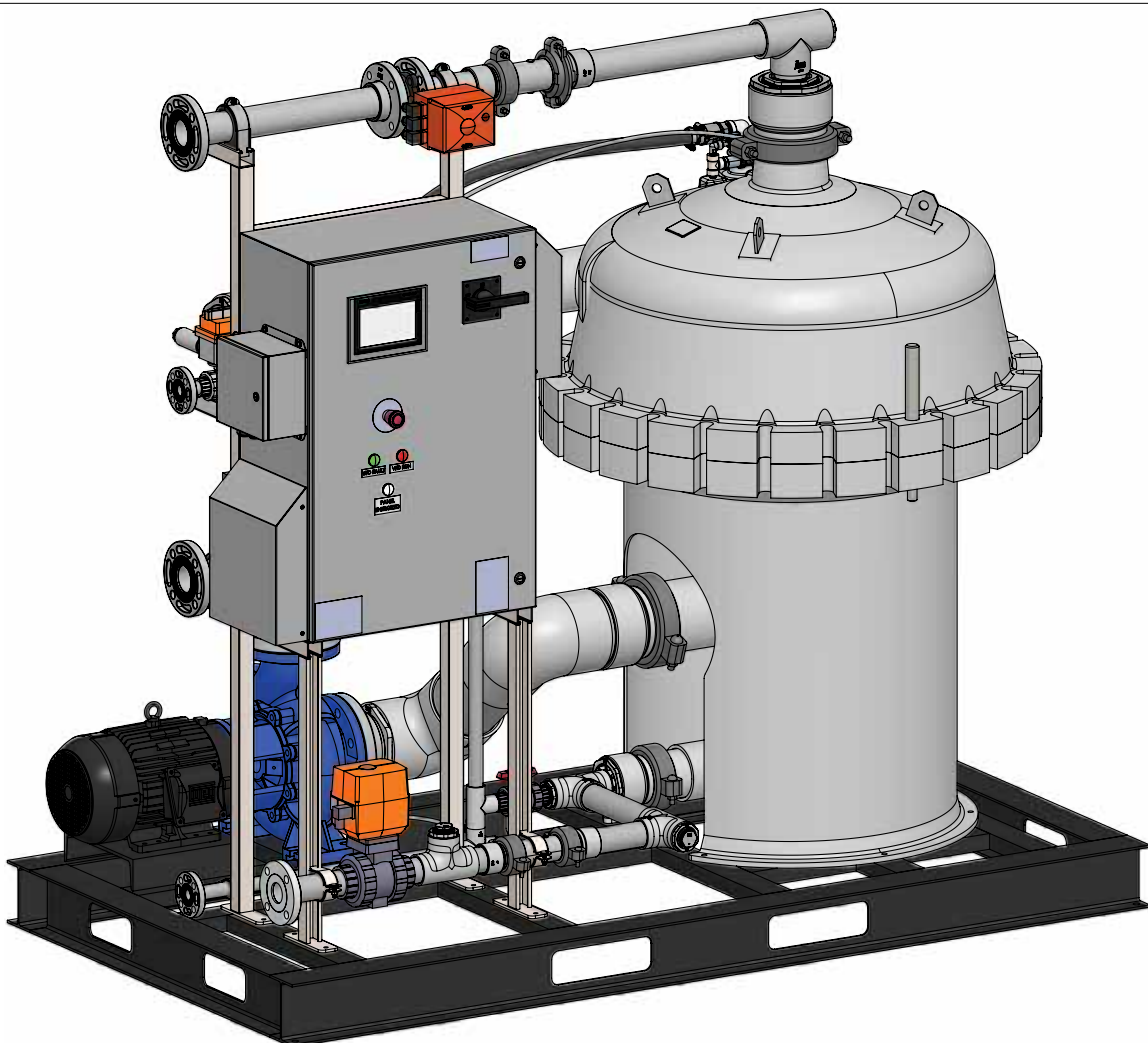

# Contents

<b>1. Introduction</b>	<b>4</b>
1.1 Safety Information	4
1.1.1 Symbols	4
1.1.2 Personnel Safety Messages	4
1.1.3 Property and Equipment Messages	5
1.2 Specifications	6
1.2.1 Dimensions	7
1.3 System Overview	8
1.3.1 Control System	8
<b>2. Installation</b>	<b>9</b>
2.1 System Configurations	9
2.2 Site Preparation	10
2.3 Unpacking the Skid	10
2.3.1 Hoisting	11
2.3.2 Placement	11
2.3.3 Plumbing	12
2.4 Electrical	12
2.5 External Controls and Sensors	13
2.5.1 Feedwater Tank	13
2.5.2 Product Tank	13
2.5.3 External Alarm	13
2.5.4 Flow Meter	13
2.5.5 Feed Pump	14
2.6 Piping and Instrumentation Diagrams	15
2.6.1 Base Diagram	15
2.6.2 Options Diagram	16
<b>3. Controls Overview</b>	<b>17</b>
3.1 Home Screen	17
3.1.1 Manual Controls	18
3.1.2 Message Center	18
3.2 Main Settings Screen	18
3.2.1 Pump Settings	19
3.2.2 Valve Settings	19
3.2.3 Tank Settings	20
3.2.4 Startup Settings	20
3.2.4.1 General	20
3.2.4.2 Air Bleed	21
3.2.5 DP/Pressure Settings	21
3.2.6 RPM Settings	21
3.2.7 Clean In Place, CIP	22
3.3 Admin Settings	23
3.3.1 Scaling Settings	23
3.3.2 User Admin	23
3.3.3 Networking	23
3.3.4 Misc	24
3.4 Clock Setting Screen	24
3.5 Alarm Screen	24
<b>4. Operation</b>	<b>26</b>
4.1 Startup	26
4.2 Shutdown	27
4.3 Long-term Shutdown	27

- 4.4 System Setup . . . . . 28
  - 4.4.1 Feedwater Pressure . . . . . 28
  - 4.4.2 Baseline Brush Speed . . . . . 28
  - 4.4.3 Filtrate Flow Rate . . . . . 29
  - 4.4.4 Concentrate Purge . . . . . 30
  - 4.4.5 Cleaning Cycle Settings . . . . . 30
  - 4.4.6 Clean In Place (CIP) . . . . . 31
- 4.5 SCADA Integration . . . . . 32
- 5. Maintenance . . . . . 35**
  - 5.1 Replacing the Filter or Brushes . . . . . 35
  - 5.2 Troubleshooting . . . . . 38
- 6. Spare Parts . . . . . 40**
  - 6.1 Filter Housing Components . . . . . 40
  - 6.2 Plumbing Components . . . . . 42
  - 6.3 Controller Components . . . . . 44
- 7. Schematic . . . . . 46**

**Questions?**

If you have questions or need more information about TEQUATIC™ PLUS Filters, please contact:

**Amiad Water Systems**

Amiad USA, INC.

120 Talbert Road, Suite J

Mooresville, NC 28117

800-648-9260

650-800-7818

E-mail: [infousa@amiad.com](mailto:infousa@amiad.com)

Website: [www.amiadusa.com](http://www.amiadusa.com)

TEQUATIC™ is a trademark of The Dow Chemical Company (“Dow”) or an affiliated company of Dow, used under license

# 1. Introduction

## 1.1 Safety Information

### 1.1.1 Symbols

It is important for you to read and understand the information in this manual prior to installation and operation of TEQUATIC™ PLUS Filter skids. This manual contains information designed to facilitate operator safety and prevent problems. The symbols below are used to reinforce key messages throughout.



**Danger:** Indicates a potentially hazardous situation which, if not avoided, will result in death or serious injury.



**Warning:** Indicates a potentially hazardous situation which, if not avoided, could result in death or serious injury.



**Caution:** Indicates a potentially hazardous situation which, if not avoided, could result in minor or moderate injury.



**Notice:** Indicates a potential situation which, if not avoided, can result in property damage or damage to the equipment.



**Note:** Indicates information, notes or tips for improving your success using the equipment.

### 1.1.2 Personnel Safety Messages

- To avoid risk of personal injury or equipment damage, please read and understand all of the safety precautions and instructions in this section and throughout this manual before servicing or operating this equipment.
- Personnel responsible for system operation and/or maintenance should attend all available safety and operator training courses. Procedures, safeguards and training should be appropriate for the types of hazards present.
- Always disconnect electrical power from the system prior to any service of the equipment, including opening of any electrical panel.
- Lockout/tagout procedures should be established and utilized as appropriate for servicing the equipment.
- Operators should be familiar with the location and use of all safety devices on the machine. Do not use the machine if it is not in proper operating condition, and report any damage or operation faults immediately.
- Make sure that the floors in the work area are dry and non-slip. Keep the work area clean to promote safety, and to avoid or identify working hazards.
- Always wear appropriate personal protective equipment (PPE), such as steel-toed shoes, safety glasses, hard hats, and long sleeves during installation, operation and maintenance of the system. Additional PPE may be required depending on the application environment and materials being used.

### 1.1.3 Property and Equipment Messages

- This equipment is not rated for hazardous locations.
- Avoid electrical hazards and damage to equipment. Install in an area where water leakage from vessel or piping will not damage sensitive equipment.
- Never operate the system at pressures and temperatures in excess of the specified rating.
- Verify all seals and internal components are properly installed.
- To avoid damage to the system or facility, repair any leaks as soon as discovered.
- Always open and close valves gradually. Auto-actuated valves should open and close in such a way as to minimize water hammer.
- Install proper safety devices in pipes and equipment carrying hot water to avoid thermal burns.
- Verifying the filter assembly and cleaning assembly are properly installed before operating the system.
- To avoid damage or hammering, expel all air from the housing and piping before startup.
- Do not start the system with filtrate line open. This will result in premature plugging of the filter membrane.
- Do not over-tighten the swing bolts when securing the housing cover. Do not exceed 80 ft-lb of torque.
- Avoid lateral loading in excess of 8 pounds to connection on the filter housing.
- Avoid long-term exposure to ultraviolet light.
- Ensure chemical compatibility of feedwater with materials and components of the system. Feedwater must be compatible with CPVC and shall not contain ozone, permanganate, or other strong oxidizing or corrosive agents.
- Always use a hoist for lifting the filter housing lid. The lid weighs approximately 500 pounds.

## 1.2 Specifications

Parameter	Value
Max Inlet Pressure	80 psi (5.5 bar)
Process Water Temperature	45 - 140 ° F (7-60 ° C) <sup>1,2</sup>
Ambient Temperature Range	32 - 100 ° F (0 - 37.8 ° C)
Maximum Altitude	6500 Ft (2000m)
Relative Humidity	95%, non-condensing
pH Range	5.0 - 9.0 continuous
Electrical, C-Series	380-480V, 50/60Hz, 3-phase, 25A
Recirculation Pump	10HP, VFD controlled
Primary Construction	Fiberglass, HDPE, Polycarbonate, SS 316, Viton O-rings, Schedule 80 CPVC, Acetal Copolymer, Powder coated carbon steel frame
<b>Dimensions</b>	
Length	92 in (234 cm)
Width	50 in (127 cm)
Height	85 5/8 in (217 cm)
<b>Weight</b>	
Dry	2380 lb (1080 kg)
Wet	3050 lb (1385 kg)
Max. Particle Size	0.07 in (2mm)
<b>Filter Element and Typical Flow Rate<sup>4</sup></b>	
SSC - 17 - 1	80 - 240 gpm (18.2 - 54.5 m3/hr)
SSC - 22 - 1	120 - 280 gpm (27.3 - 63.6 m3/hr)
SSC - 27 - 1	160 - 320 gpm (36.3 - 72.7 m3/hr)
<b>Piping Size</b>	
Inlet	2.5 in Class 150 Flange (DN65-PN16)
Filtrate	2.5 in Class 150 Flange (DN65-PN16)
Concentrate Purge	2 in Class 150 Flange (DN50-PN16)
Service Drain	1 in Class 150 Flange (DN25-PN16)
CIP Inlet	1 in Class 150 Flange (DN25-PN16)
CIP Chemical Inlet	1/2" in FPT

1 Consult factory if operational temperatures are required above this range.

2 Actual operating temperature range may be narrower depending on feedwater composition.

3 Consult factory if operational pH is required outside of this range.

4 Flow rate will vary depending on water quality.

### 1.2.1 Dimensions

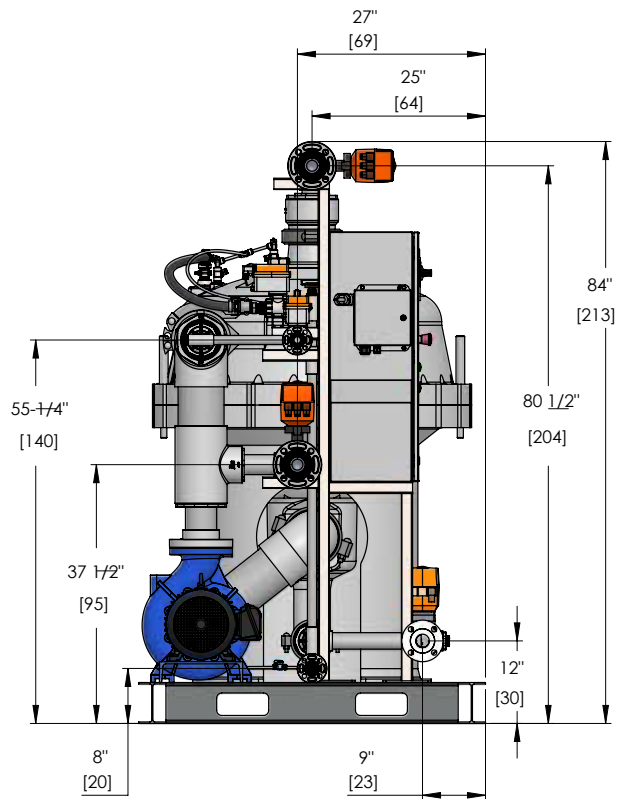
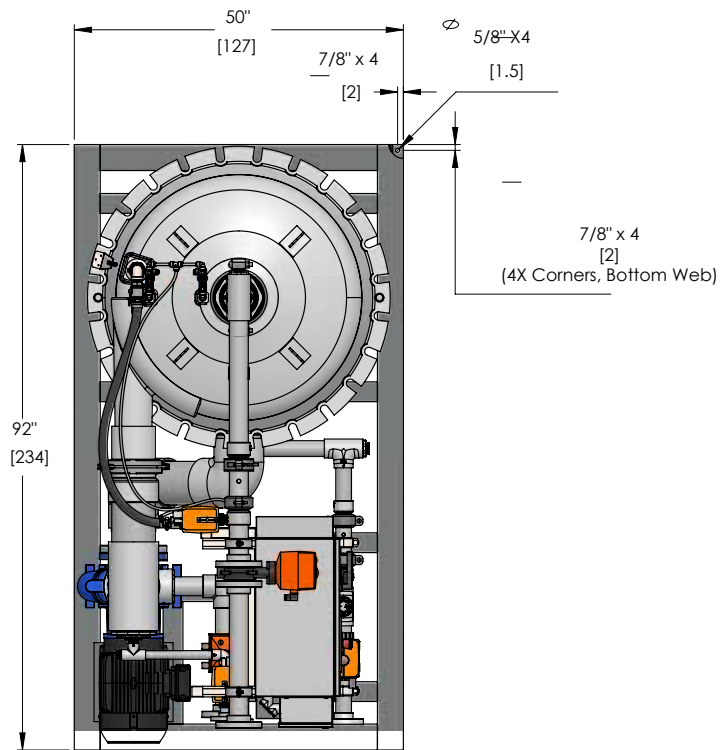

### 1.3 System Overview

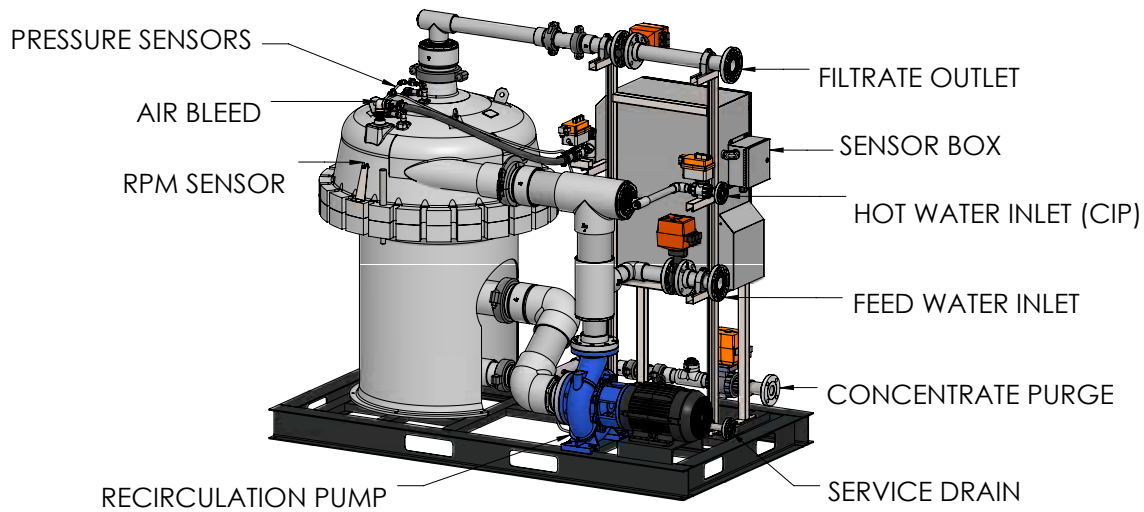
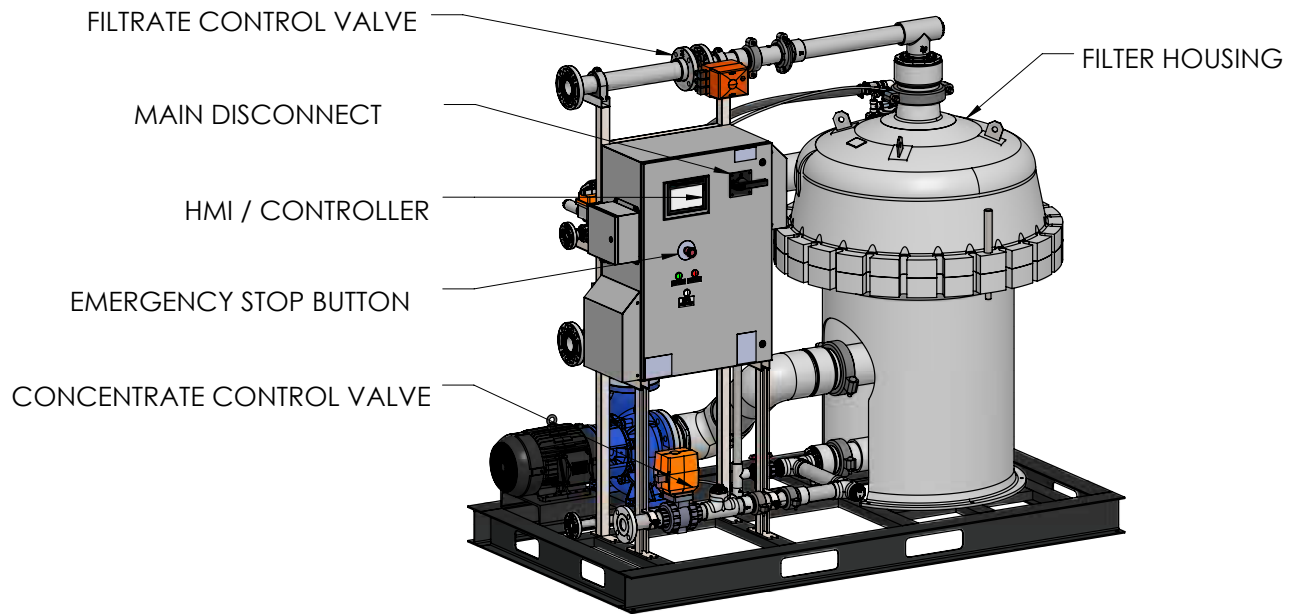

#### 1.3.1 Control System

The controller provides the operator interface for the system and controls the operation of the various valves, sensors, and pump. The PLC and VFD are located in the main enclosure with the main disconnect and the HMI screen. The small side enclosure is for all field connections and only has 24VDC present.



## 2. Installation

### 2.1 System Configurations

The configuration of the TEQUATIC™ PLUS F-150 C-Series skid will depend on the purpose of the system as well as the scale. The system can be a single skid, or multiple parallel skids for larger scale. The optimal configuration will be site-specific, but should include some of the following aspects:

- **Parallel Systems:** When parallel systems are employed, it is recommended that valving be utilized on all lines to permit isolation of any single system for maintenance. Check valves should also be utilized to prevent one system backfeeding into another system.
- **Preconditioning:** Preconditioning may be required for process water that falls beyond the scope of the system. This may include, but is not limited to, prescreening of large particulate material greater than listed in the specifications section above.
- **Feedwater Supply:** The feedwater is best supplied from a holding tank. The feed tank will buffer variations of influent flow with time, and if recommended, it also permits the concentrate to be returned back to the tank for greater filtration efficiency. The feedwater supply to the skid needs to be pressurized. This is typically accomplished with a pressure-controlled pump. The skid controller has a pump control dry contact, as well as a feed-tank-low sensor input.
- **Filtrate Effluent:** The filtrate effluent is the primary treated discharge from the system, and should not have appreciable back pressure. This line contains a system-controlled valve. This is typically best served with a holding tank to accommodate variations in flow. A tank-full sensor dry contact input is available for monitoring the status of the filtrate tank.
- **Concentrate Purge:** The concentrate purge is a system-controlled, pressurized discharge of the primary filtration concentrate. The discharge point should be open-air or other sump means for disposal or further processing.
- **Service Drain:** The service drain is manually controlled, and must be non-pressurized and located entirely below the height of the system. The discharge should be open-air or fully vented, and capable of receiving (expelling) air pressure during a system bleed operation.
- **Concentrate Return:** In some cases, a portion of the processed water can be returned back to the feedwater tank, called the concentrate return. This is manually controlled, and should be a non-pressurized line. To prevent this line from draining the system, it should be elevated above the height of the tank and contain a siphon break located above the height of the system, such as an open-air discharge back into the tank.

## 2.2 Site Preparation

Before the physical installation of the system, it is important to make sure the installation area is properly configured for accessing the system. The allotted space should include the physical requirements of the equipment plus additional space for working and maintenance clearance.

At a minimum, the area in front of the control panel should be left open to permit the operator access for daily operation. Additional space may be required for local codes.

Maintenance clearance around the system is more subjective and may vary depending on the frequency of maintenance tasks. When planning the space, consider having extra clearance near the pump to facilitate removal or servicing.

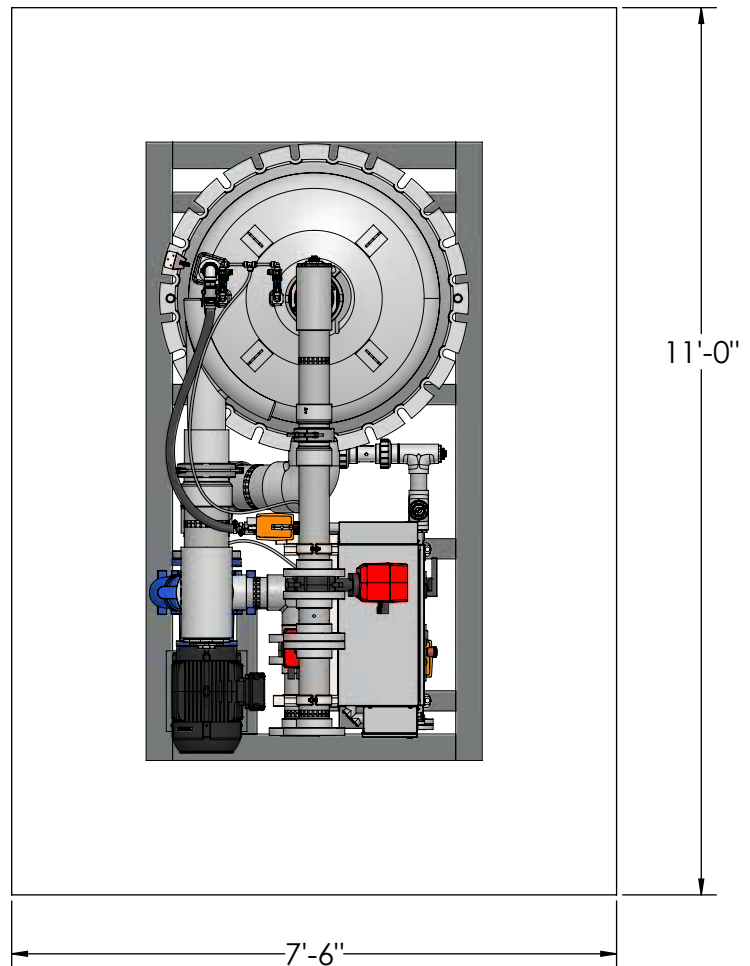

## 2.3 Unpacking the Skid



**Notice:** Be careful when working around the filter housing with tools to avoid damaging the housing. Also, take care not to disturb the pressure and speed sensors on the upper filter housing.



**Note:** Shipping damage must be noted at the time of receipt, and claims made to the freight company.

- Remove all packing materials from the skid and inspect the system for shipping damage.
- Inspect all of the plumbing lines and fittings to ensure they are firmly tightened and undamaged.
- Inspect the controller cabinet to ensure that all components are firmly in place and no wires have loosened.
- If the system was shipped on a pallet, remove any strapping and lag bolts, and lift the system off the pallet using the lifting points shown in the following section.

### 2.3.1 Hoisting

Hoisting and transporting the skid must be completed in a manner that maintains stability and does not cause damage to the components. The primary lifting method is intended to be forklift or pallet jack. Note the following for lifting and transporting:

- When lifting from the side, make sure the forks are spread as far as possible for better stability. Make sure the forks are long enough to reach under the opposite frame rail.
- Lift under the skid frame. Do not lift by any component or plumbing fixture.
- Do not tilt the system beyond 10°
- Lifting from the end should not be attempted unless the forks are long enough to reach the second internal frame member past the center of the skid.
- For hoisting, use a lifting frame to avoid the straps or chains from binding against system components.
- Remove any fittings or fixtures that could become damaged from the hoist.
- Lift only from the frame of the skid, and do not secure straps or chains to any components or plumbing fixtures.



### 2.3.2 Placement

The skid should be placed on a level floor surface such that all four corners are even, to prevent twisting of the frame and reduce stress on any internal plumbing fixtures. Skid must be bolted down using min. 3/8" hardware with Min. 2300lbs shear strength.

### 2.3.3 Plumbing

Plumbing into the TEQUATIC™ PLUS Filter skid system uses 1, 2, and 2.5 inch class 150 ANSI flanges that will allow the installation of fittings to adapt into the facility plumbing. The actual plumbing layout will depend on the complete system design.

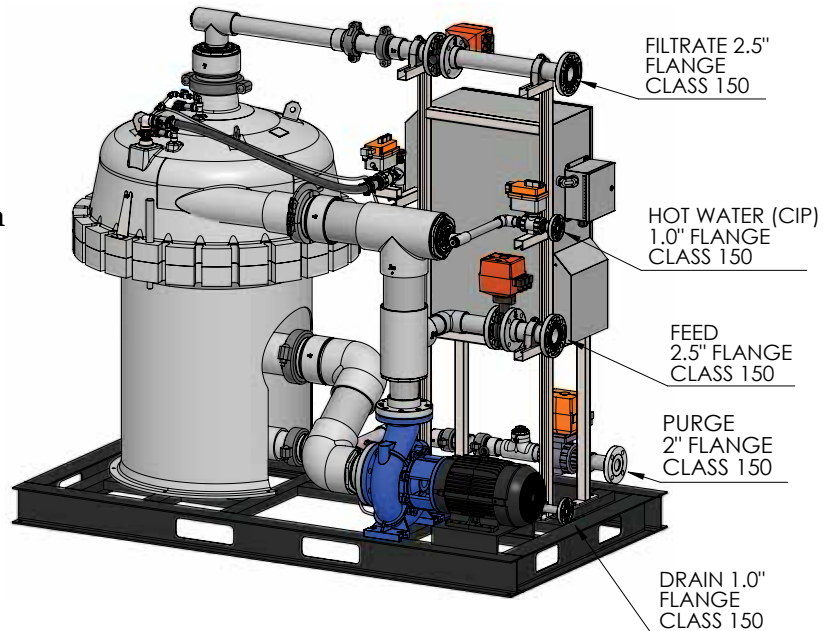

### 2.4 Electrical

The system requires a 3-phase, grounded supply circuit.

Make sure the circuit is installed in accordance with all applicable electrical codes.

The main disconnect lugs are rated for stranded copper, up to 3/0 maximum conductor size. All conductors must be rated for 75°C.

**i** **Note:** The actual enclosure layout may vary slightly depending on system voltage considerations.

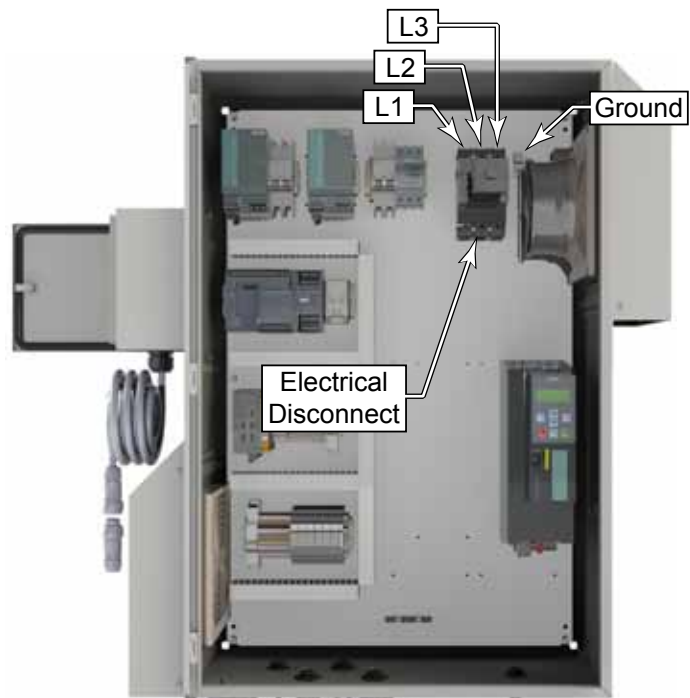

## 2.5 External Controls and Sensors

The following are external controls and sensors for the system that are not included with the skid.

### 2.5.1 Feedwater Tank

To prevent the system from running dry, the system can incorporate a feedwater tank level switch. The sensor selection should be appropriate for the water conditions present. The sensor should supply an “open” or “closed” circuit, dry contact, to indicate the no-run condition. The control system will send +24VDC to the sensor and look for the same signal to return to indicate a closed circuit. Logic can be selected in the HMI settings screen. Refer to “[Tank Settings](#)” on page 20 for all options and setpoints for sensor.

### 2.5.2 Product Tank

To help prevent the tank overflow, an output tank from the skid (effluent or concentrate) can incorporate a tank level switch. The sensor selection should be appropriate for the water conditions present. The sensor should supply a dry contact to indicate the no-run condition. The control system will send +24VDC to the sensor and look for the same signal to return to indicate a closed circuit. Logic can be selected in the HMI settings screen. Refer to “[Tank Settings](#)” on page 20 for all options and setpoints for sensor.

### 2.5.3 External Alarm

An external alarm may be connected to the system to alert an operator of a problem with the system. The alarm may be audible, visual or both. This relay output is a normally-open contact closure (dry contact).

### 2.5.4 Flow Meter

An optional flow meter with 24VDC pulse or 4-20mA analog output may be connected to the system to measure the filtrate flow rate. The pulse output must be settable in the format of maximum frequency with the corresponding flowrate. The analog output must be settable by assigning a flow rate to the 20mA signal, 4mA will be assumed 0 flow. Refer to “[Scaling Settings](#)” on page 23 for setting options.

## 2.5.5 Feed Pump

The filter skid is designed to operate with a constant feed pressure between 30 and 80 psi that is maintained as flow changes with minimal pressure variation. In the case where this type of feed water is not available a dedicated feed pump should be used. The feed pump should be pressure controlled using a VFD with a pressure sensor and a closed loop, PID feedback system. The filter skid will provide a dry contact to control the on/off function of the feed pump but the speed control must be self contained in the feed pump VFD PID software.

Below are the design considerations that must be addressed when building a feed pump skid.

- The pump selection should be capable of delivering 130% of the desired filtrate flow rate while maintaining a minimum of 30 psi inside the filter housing.
  - Pressure drop from the feed pump to the filter skid must be taken into account when sizing the feed pump.
  - In the case of multiple filters fed by a single feed pump reduce the feed pump flow requirement by 5% for each additional filter. It is recommended that a maximum of 4 filters be served by a single feed pump. The feed pump flow capacity can not drop below 110% of the combined filtrate flow rates.
- The feed pump VFD should have inputs for a remote on/off command. The command will be given by a dry contact within the filter skid control system; closed = on, open = off.
- The feed pump VFD should have adjustable ramp-up and ramp-down functions. The recommended initial values are Ramp-up = 30 seconds, and Ramp-down = 5 seconds. The pump should build pressure slowly but, be able to drop pressure quickly if flow stops.
- The feed pump VFD must have an analog input to reference a pressure sensor and associated PID function to maintain a pressure set point.
  - Depending on the VFD and pressure sensor combination, the VFD likely needs the ability to invert and bias the output speed such that the pressure versus speed are inverse functions.
  - The proportional gain should be set high enough to accurately reach the setpoint but, set low enough to prevent oscillations (hunting) near the set point.
  - The pressure set point must be adjustable for tuning the desired pressure.
- The feedback pressure sensor should be located as close to the pump outlet as possible to provide accurate pressure control.

Any feed pump setup must be tested prior to installing a filter. The testing should include verification the VFD can maintain a setpoint, verification the pump speed can adjust as flow requirements change, and verification the VFD can accept the on/off commands from the filter skid.

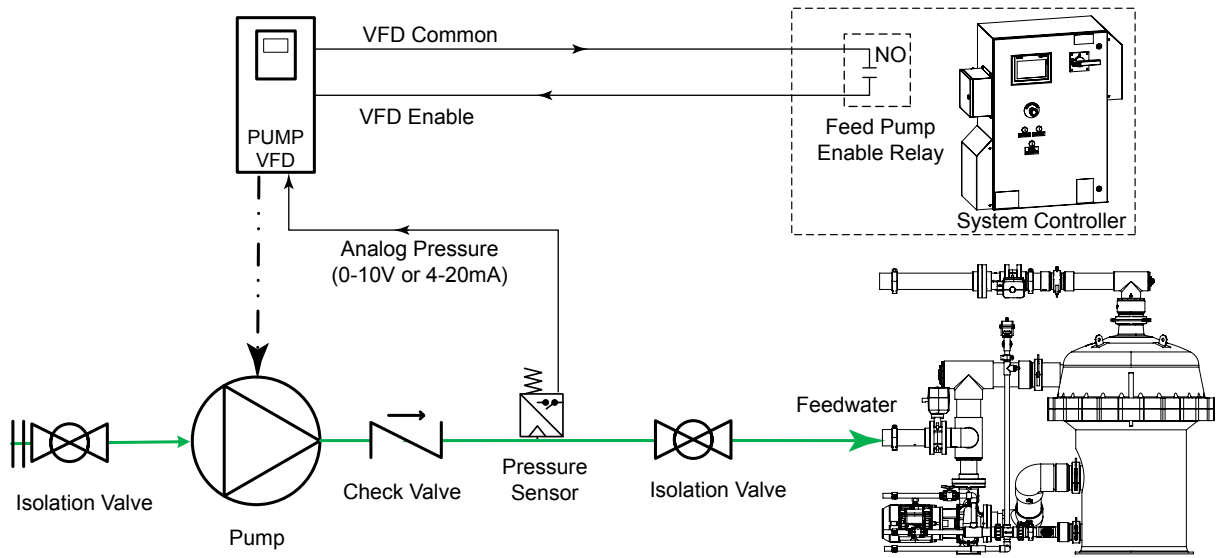

## 2.6 Piping and Instrumentation Diagrams

### 2.6.1 Base Diagram

The piping and instrumentation diagram below represents the configuration of the basic system without optional features.

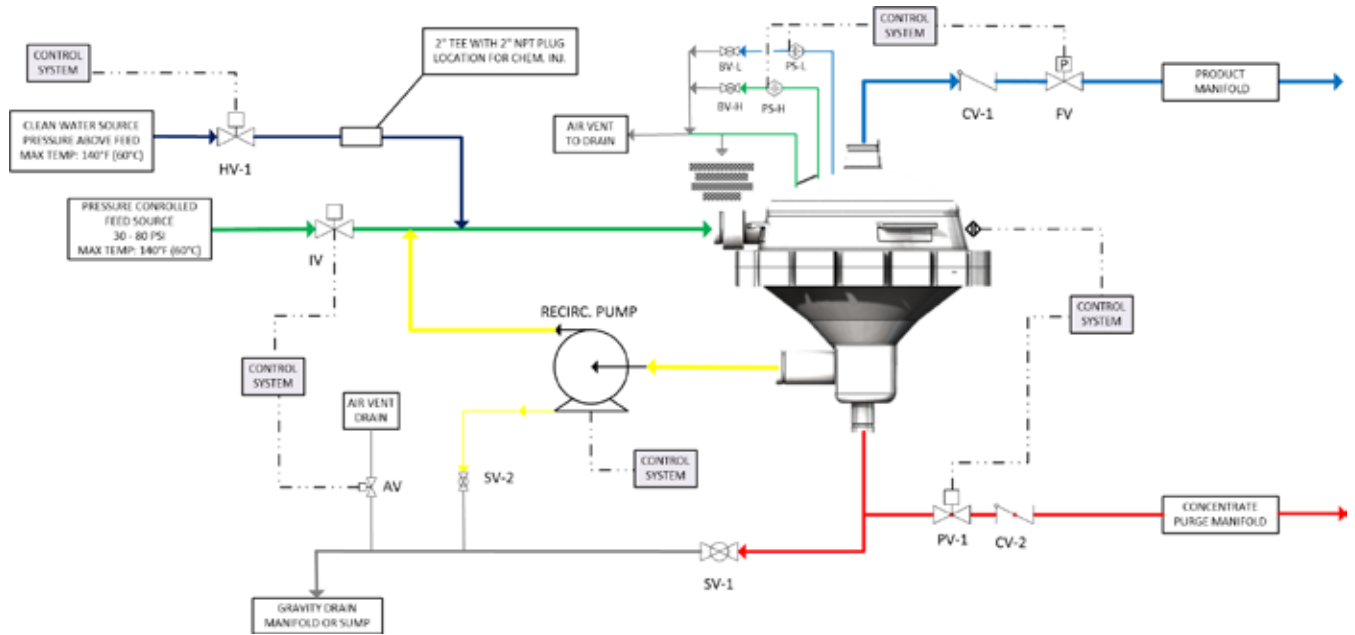

SYMBOLS LEGEND	
AV = AIR VALVE	IV = INLET VALVE: FEED
BV-H = BLEED VALVE: HIGH PRESSURE	LS-F = LEVEL SWITCH: FEED
BV-L = BLEED VALVE: LOW PRESSURE	LS-P = LEVEL SWITCH: PRODUCT
CV-1 = CHECK VALVE: FILTRATE	PS-H = PRESSURE SENSOR: LOW PRESSURE
CV-2 = CHECK VALVE: CONCENTRATE	PS-L = PRESSURE SENSOR: HIGH PRESSURE
FC = FILTRATE FLOW CONTROL VALVE	PV-1 = PURGE VALVE: CONCENTRATE
FS = FILTRATE FLOW SENSOR*	SV-1 = SERVICE VALVE: SKID
FV = FILTRATE VALVE	SV-2 = SERVICE VALVE: PUMP
HV = HOT WATER VALVE: CIP	

\*Customer installed option

ELECTRICAL SYMBOLS	
	PRESSURE SENSOR
	RPM SENSOR
	LEVEL SWITCH (DOWN)
	LEVEL SWITCH (UP)

PLUMBING SYMBOLS			
	GENERAL VALVE		FILTRATE
	ACTUATED VALVE		FEED
	BALL VALVE		RECIRCULATION
	CHECK VALVE		CONCENTRATE
			DRAIN
			WATER INLET
			CLEAN IN PLACE
			WIRING
			CENTRIFUGAL PUMP

### 2.6.2 Options Diagram

The piping and instrumentation diagram below represents the configuration of the system with all optional features shown. Depending on the actual system configuration, some options will not be present on all systems.

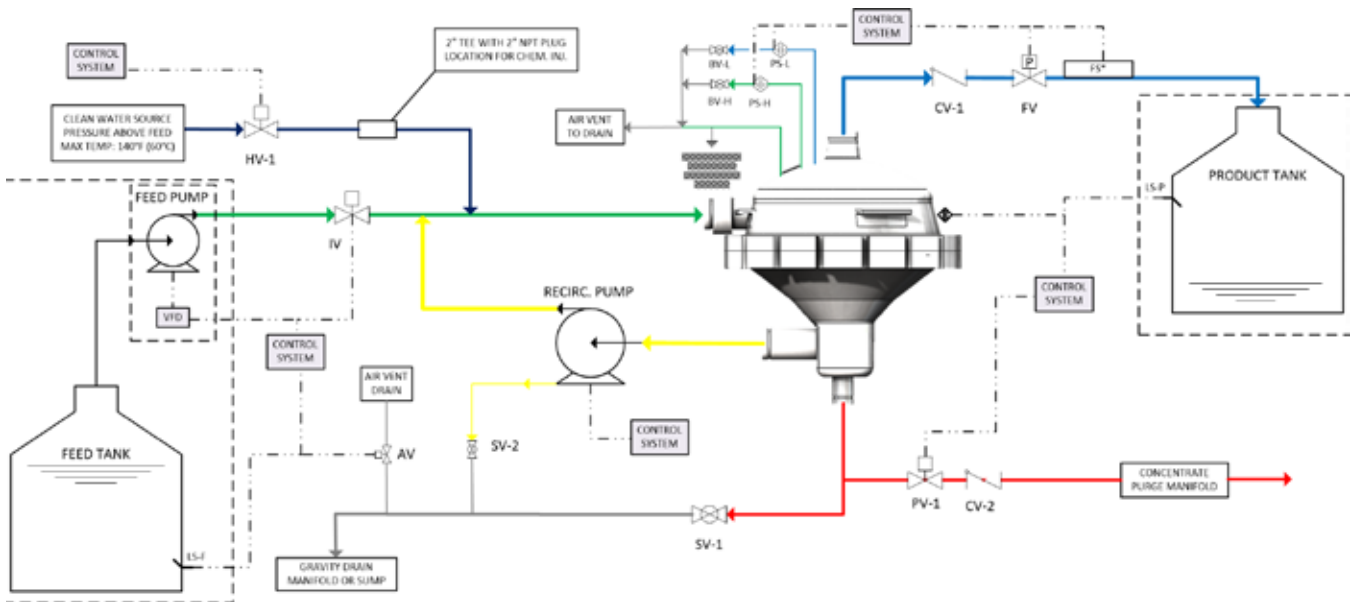

SYMBOLS LEGEND		ELECTRICAL SYMBOLS	PLUMBING SYMBOLS
AV = AIR VALVE	IV = INLET VALVE: FEED	⊕ PRESSURE SENSOR	⊗ GENERAL VALVE
BV-H = BLEED VALVE: HIGH PRESSURE	LS-F = LEVEL SWITCH: FEED	⬠ RPM SENSOR	⊠ ACTUATED VALVE
BV-L = BLEED VALVE: LOW PRESSURE	LS-P = LEVEL SWITCH: PRODUCT	⎓ LEVEL SWITCH (DOWN)	⊘ BALL VALVE
CV-1 = CHECK VALVE: FILTRATE	PS-H = PRESSURE SENSOR: LOW PRESSURE	⎓ LEVEL SWITCH (UP)	∇ CHECK VALVE
CV-2 = CHECK VALVE: CONCENTRATE	PS-L = PRESSURE SENSOR: HIGH PRESSURE		
FC = FILTRATE FLOW CONTROL VALVE	PV-1 = PURGE VALVE: CONCENTRATE		
FS = FILTRATE FLOW SENSOR*	SV-1 = SERVICE VALVE: SKID		
FV = FILTRATE VALVE	SV-2 = SERVICE VALVE: PUMP		
HV = HOT WATER VALVE: CIP			
*Customer installed option			
			— FILTRATE
			— FEED
			— RECIRCULATION
			— CONCENTRATE
			— DRAIN
			— WATER INLET
			— CLEAN IN PLACE
			— WIRING
			⊕ CENTRIFUGAL PUMP



### 3. Controls Overview

The TEQUATIC™ PLUS F-150 C-Series Skid system is operated with a PLC controller and touch screen display. The display provides status information about the system and also the primary operator interface. The functions of the operator interface are presented on various screens, which are described in the sections below.

Each screen contains a set of navigation buttons (Home, Settings, Clock, Alarms) for moving to the various other screens. Touching any of these four buttons will navigate the display to the applicable screen. These screens and their purposes are described in subsequent sections. Software can be updated as improvements are made. Actual screens may vary slightly as improvements are made.

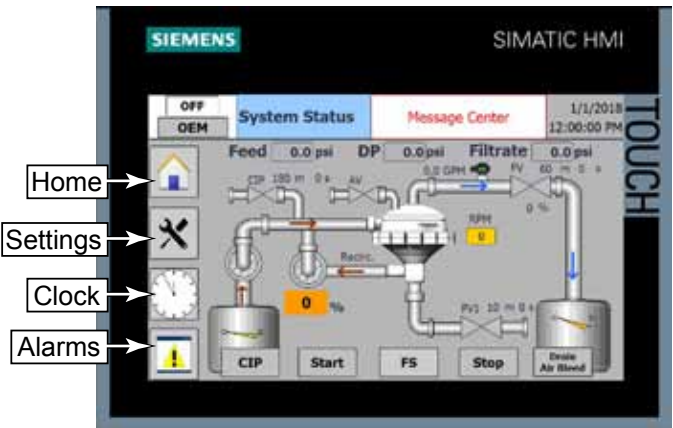

#### 3.1 Home Screen

The home screen provides a visual snapshot of the system operation, and serves as the primary Start and Stop function of the system. The home screen also provides manual control of the various pumps and valves. The individual functions are described below. Components will be displayed or hidden depending on whether they are enabled or disabled.

- A. CIP Kit Hot Water Valve Status
- B. Housing Pressure (High Pressure)
- C. Time Until Next Scheduled CIP Event
- D. Differential Pressure Across Filter Screen
- E. Message Center
- F. Cleaning Assembly RPM
- G. Filtrate Valve Status
- H. Filtrate Pressure (Low Pressure)
- I. Time Until Next Scheduled Forward Spin Event
- J. Feed Tank
- K. CIP Trigger Button
- L. Recirculation Pump Speed (Percent Of Maximum)
- M. System Start Button
- N. Manual Forward Spin Trigger Button
- O. Purge Valve 1 Status

- P. System Stop Button
- Q. Time Until Next Scheduled Purge Event
- R. Drain and Air Bleed Button
- S. Product Tank

*Some items shown below may not be present on all systems, depending on installed options.*

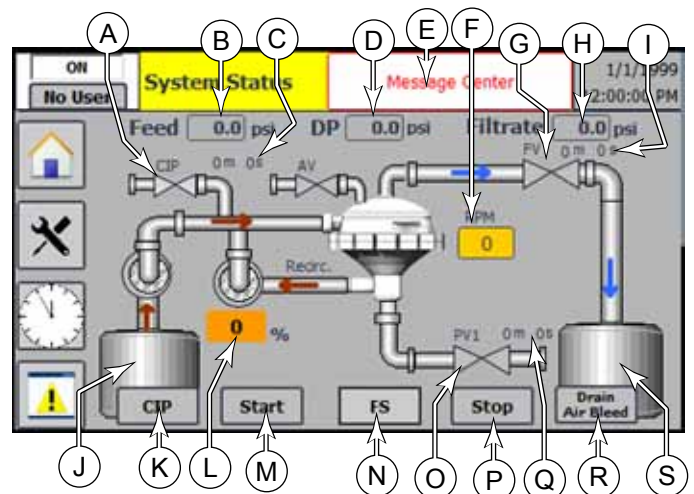

### 3.1.1 Manual Controls

Individual pumps and valves may be manually operated from the home screen. This can be helpful for tuning the system or for troubleshooting and testing devices.

To manually operate a device, touch the icon representing the pump or valve. A pop-up dialog will be displayed. If the device is not available for manual operation, it will be listed as Disabled at the top of the dialog. The device needs to be enabled before it can be manually controlled.

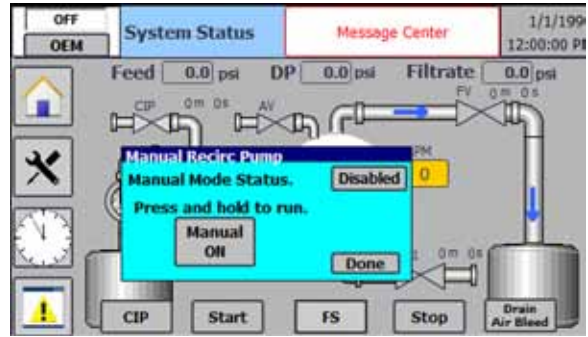

If the device has speed or other rate of operation, set that value by touching the dialog to open a numeric keypad. Type in the desired value and press Enter.

The dialog will indicate whether the On button is a momentary button or a toggle button. For a momentary button, the device will remain active only for as long as you hold the button. For a toggle button, the device will toggle on and off each time you touch the button.

### 3.1.2 Message Center

The message center will communicate any action that is being taken by the system. The message will change while in an event, such as Startup, and will detail how much time is left and/or what step in the event the system is in.

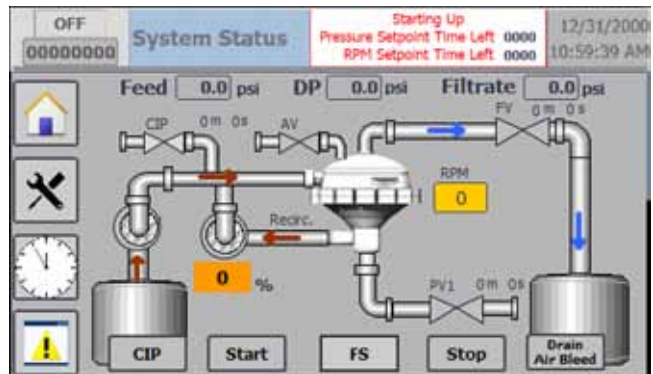

## 3.2 Main Settings Screen

The main settings screen provides navigation to each of the individual setting screens. The individual setting screens are listed below and in the subsequent sections.

- [Pump Settings](#), page 19
- [Valve Settings](#), page 19
- [Tank Settings](#), page 20
- [Startup Settings](#), page 20
- [DP/Pressure Settings](#), page 21
- [RPM Settings](#), page 21
- [Clean In Place, CIP](#), page 22
- [Admin Settings](#), page 23
  - [Scaling Settings](#), page 23
  - [User Admin](#), page 23
  - [Networking](#), page 23
  - [Misc](#), page 24

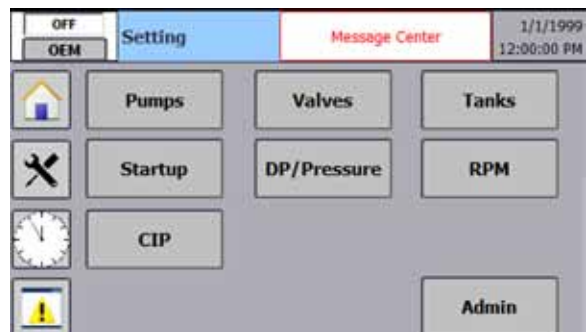

### 3.2.1 Pump Settings

The pump settings can be adjusted in this screen. The recirculation pump is standard to the C-Series skid and should always be enabled. The system will send a run command to an external feed pump by enabling the feed pump. The fault delay is the time allowed between sending a run command and receiving feedback before a fault is triggered. Start and stop delays are intended for custom applications and should remain set to zero. The speed of the recirculation pump can be set here as a percent of the maximum available speed for the pump.

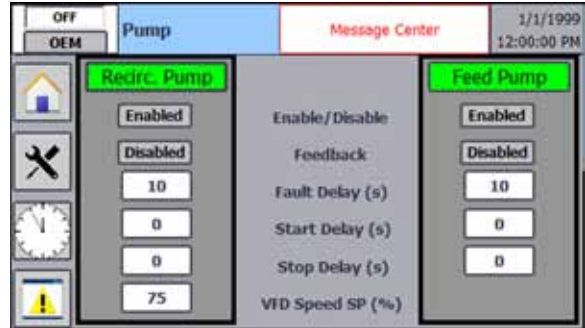

### 3.2.2 Valve Settings

This screen sets the basic parameters for any installed valves. Touch the valve name to select which of the installed valves to view the settings for. This will be Filtrate Valve (Manual, DP, or Flow) and Purge Valve.

- **Enable/Disable:** Sets whether the valve is available to the system or not.
- **Feedback:** Sets whether the valve is capable of feedback (open/closed/position) and whether this feedback is available to the system.
- **Fault Delay:** Once a valve has been signaled to close, the PLC will look for feedback to confirm complete cycling of the valve. If feedback is not received once the delay timer has expired a fault will be triggered.
- **Schedule:** Sets whether the valve should function on a timed schedule.
  - **Frequency:** Sets how often (in minutes) the valve should be operated when Schedule is enabled.
  - **Duration:** Sets how long (in seconds) the valve should be operated when Schedule is enabled.

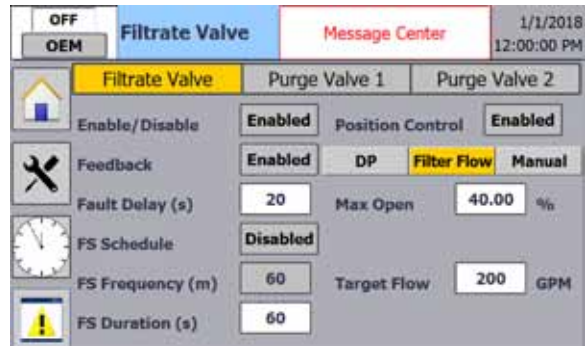
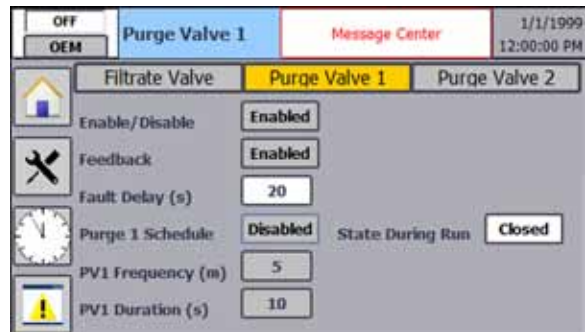

### 3.2.3 Tank Settings

This screen sets the basic parameters for any installed tank level switch. The switches must be dry contact (open or closed circuit) type switches. The logic for switch condition to run condition can be set according to the switch setup.

- **Enable/Disable:** Sets whether the tank sensor is available to the system or not.
- **Stop Delay:** The tank level switch must remain in the “no run condition” for the specified delay time before the system will take action from the input. This is intended to eliminate nuisance shutdowns due to water turbulence.
- **Shutdown Delay:** This value sets the time delay between when the product tank is full and when the system shuts down. This provides an opportunity for the tank to catch up without a premature shutdown.
- **Automatic Restart:** Sets whether the system will automatically restart after the sensor condition has cleared.
- **Restart Delay:** With automatic restart enabled and after a tank switch shutdown, the switch must remain in the run position for the delay time before any action is taken. This is intended to stagger restart and prevent premature restart.
- **Switch for Run:** This option allows the circuit logic for the switch to be changed. For example, if Open is selected the switch must provide an open circuit for a run condition.

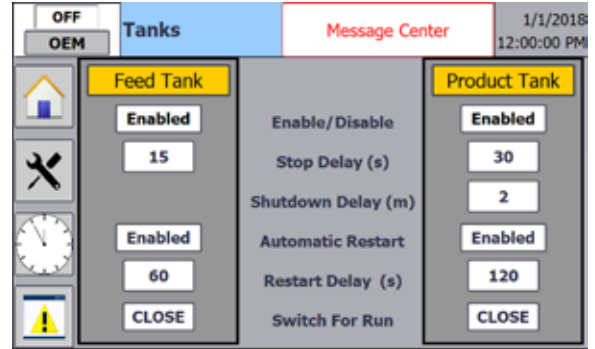

### 3.2.4 Startup Settings

This screen sets the parameters for system startup. Touch the General or Air Bleed tab to open the appropriate sub-screen.

#### 3.2.4.1 General

- **Startup Feed Pressure:** This is the minimum pressure that must be reached in the housing for startup event to continue.
- **Startup Feed Pressure Delay:** This is the time allowed for the system to reach the pressure setpoint. If the timer expires before the pressure is reached startup will be aborted.
- **Startup Speed:** This is the minimum cleaning assembly speed that must be reached for the startup event to continue.
- **Startup Speed Delay:** This is the time allowed for the cleaning assembly to reach the minimum speed requirement. If the timer expires before the RPM is reached startup will be aborted.
- **Startup Time:** Once both minimum setpoints are reached the system will dwell for the time specified. This will allow the system to clean and then purge any contaminants off the screen before entering normal operation.

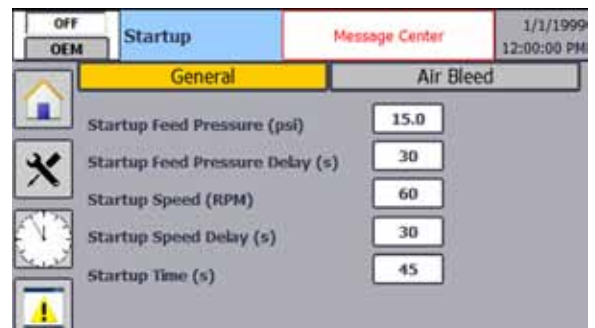

### 3.2.4.2 Air Bleed

- Air Bleed Valve: Enables the use of an air bleed valve after one is installed.
- Water Inlet Valve: Enables the use of a water inlet valve after one is installed.
- Feed-Pump Bleed: If enabled the system will trigger the feed pump to activate when bleeding air.
- Preliminary Air Bleed can be done manually by touching the AV symbol on the home screen. The feed pump will supply the pressure if enabled.
- Automatic Air Bleed: If enabled the system will automatically trigger an air bleed event after the start command is given and before the general startup event begins. The air bleed event will open the air bleed valve, open the water inlet valve, and trigger the feed pump if enabled.
- Air bleed Duration: This is the amount of time the system will keep valves open and feed pump on to complete air bleeding. This value should be experimentally determined for each installation and tuned for feed water characteristics.
- Air bleed valve close delay: Once the air bleed duration expires and general startup event begins, the air bleed valve can be kept open for a set amount of time to ensure all air is out of the system.

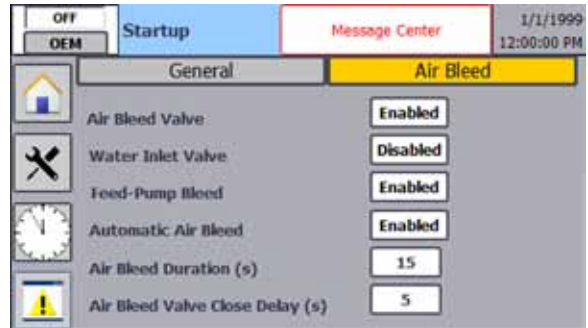

### 3.2.5 DP/Pressure Settings

The DP/Pressure settings screen lists various parameters related to the filter operation and associated alarm thresholds.

- High DP: This setting determines the differential pressure value necessary to trigger a cleaning cycle. The differential pressure represents how much resistance to water flow is through the filter. A high differential pressure indicates the filter is becoming clogged. (See [page 30](#).)
- Max DP Events/Period: This sets the maximum number of High DP events permitted per time period (in minutes) before an alarm is triggered.
- High Feed Pressure: This setting determines the upper alarm limit for the feed pressure sensor.
- Low Feed Pressure: This setting determines the lower alarm limit for the feed pressure sensor.

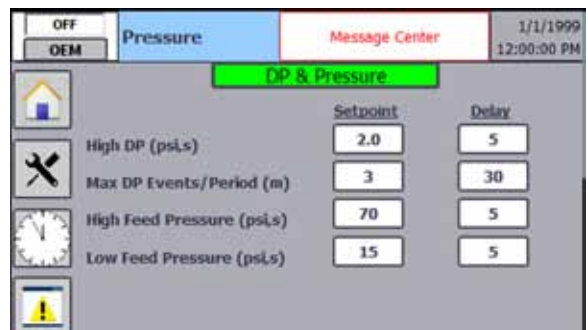

### 3.2.6 RPM Settings

- Low Brush Speed: This setting determines the brush speed that results in a low speed alarm. The brush speed represents the rate of water flow through the filter housing. If the brush speed is less than the setpoint, the system will shut down.
- Max RPM Events/Period: This sets the maximum number of RPM alarms for a given period, before the system shuts down.

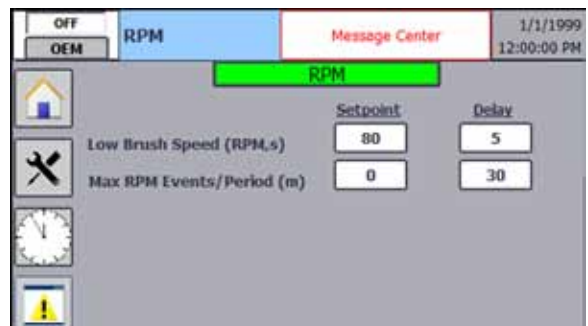

### 3.2.7 Clean In Place, CIP

This screen allows all settings for the CIP event to be set. This function requires an add-on kit that includes additional valves, plumbing, and wiring. With the components installed the proper function can be utilized.

- Chem Duration, Dwell Duration, Pause Duration, and Filtrate Bump will adjust the timing of the action taken during the CIP event. The valve action diagram shown below describes the interactions of these settings.
- Schedule: When enabled, this will trigger a CIP event based on the Frequency timer.
- Cycles: This determines the number of CIP cycles that occur during a single CIP event.
- Shutdown CIP: Enabling this will trigger a CIP event whenever the system is shut down at the HMI screen. It is not recommended to be used in conjunction with a tank level switch and automatic restart.
- DP Event CIP: This will trigger a CIP event instead of a forward spin in the case of high differential pressure event.
- Max CIP Events/Period: If the maximum CIP Events per time frame is exceeded the system will not perform the CIP but will continue running. This is intended to limit chemical usage and system downtime.

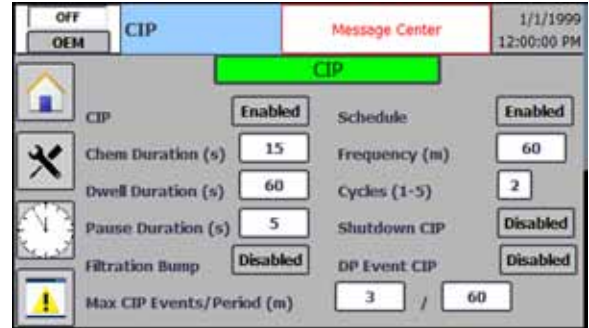

**CIP Valve Action Diagram**

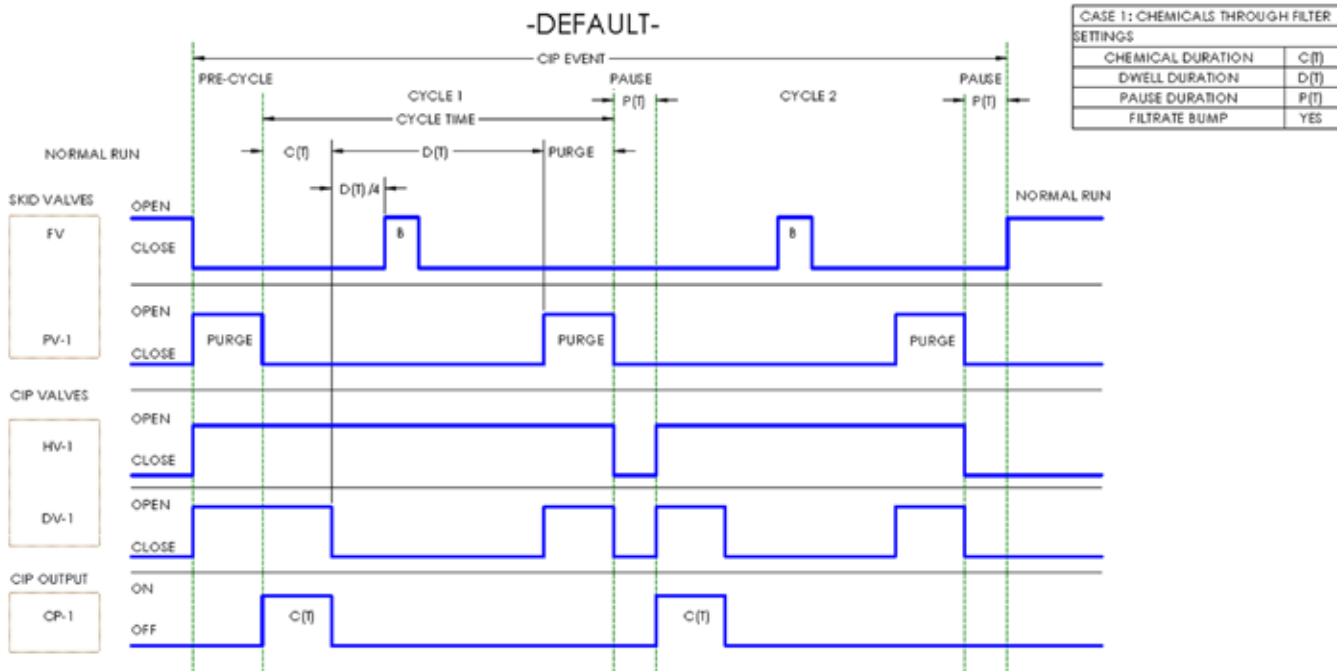

### 3.3 Admin Settings

This screen sets the general parameters of the system, which are described in the sections below.

Access to this section is restricted to only administrator access levels and should only be adjusted by an Amiad technician.

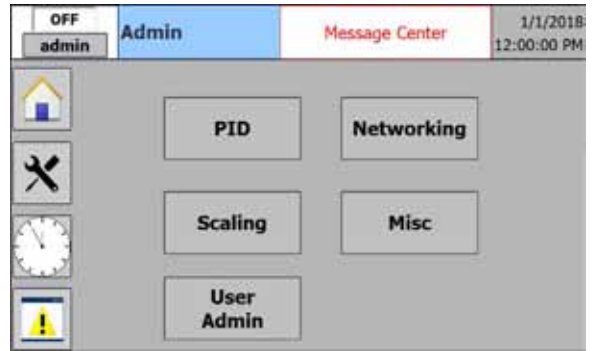

#### 3.3.1 Scaling Settings

This screen is for setting system parameters in their native electrical units. With the exception of filtrate flow, the values on this screen should not be altered.

If an optional flow meter is installed, the system needs to know the volumetric unit of measure per flowmeter pulse, in order to establish a flow rate value from the count of pulses.

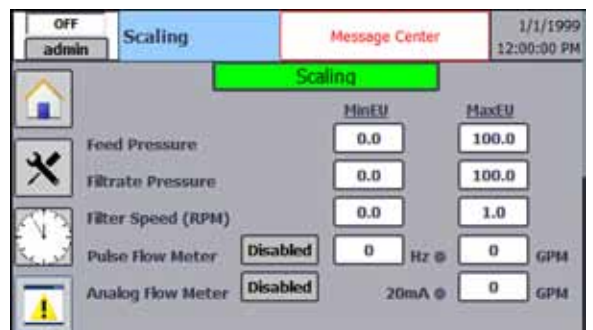

#### 3.3.2 User Admin

This screen allows users to be added and removed from the system. To add a user select the next available cell on the bottom of the “User” list and enter a new user name. The password, authorization group, and logoff time can then be assigned.

Username	Password	Group	Logoff
OP	OPP	Operator	5
OEM	OEM	Supervisor	5
Admin	†	Administrator	5



† Administrator password can be requested from Amiad service.



**Notice:** Do not delete all users or the system cannot be operated and a technician will need to reload the software in the unit.

#### 3.3.3 Networking

This screen allows network and IP settings to be set. These settings will allow the unit to be linked into a facility SCADA system. These settings should only be changed by Amiad technicians as each application is unique.

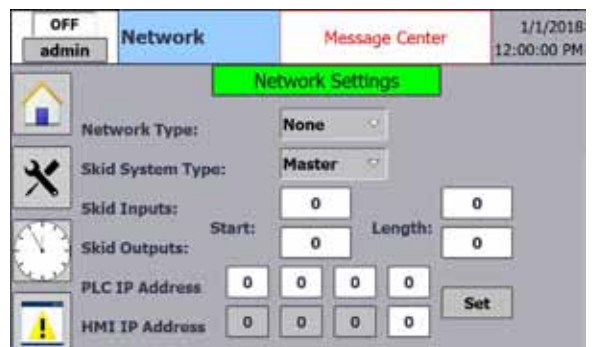

### 3.3.4 Misc

- Units Select: This sets the operator display units between imperial units (U.S.) versus metric units.
- External Alarm: This sets whether an external alarm, such as a beacon lamp, is available to the system.
- Housing Size: The housing size option allows all settings in the system to be changed to a preset value defined by housing size or 3 custom selections. This function is intended to be used by pilot or custom units and should not be changed.

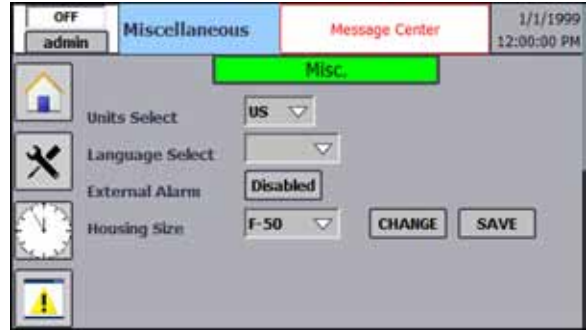

### 3.4 Clock Setting Screen

This screen is used for setting the system date and time. Touch each entry box to open a numeric keypad pop-up screen to enter a new value.

**Note:** The current software version is displayed in the upper right corner. This information may be requested by a technician.



### 3.5 Alarm Screen

The alarm screen provides access to the current active alarms, as well as the alarm log history.

The active alarm screen will show any alarms that are currently active on the unit. These must be cleared in order to continue running. The alarm log will display all alarms and warnings that have been triggered by the system. This can be helpful to identify run time of the unit and performance of tank level switches. If the alarm log is blank check that the SD card is installed in the HMI inside of the control panel.

All active alarms must be clear for the system to start and run. To clear an alarm that no longer has the trigger event present press the tile that shows a table with a check mark.

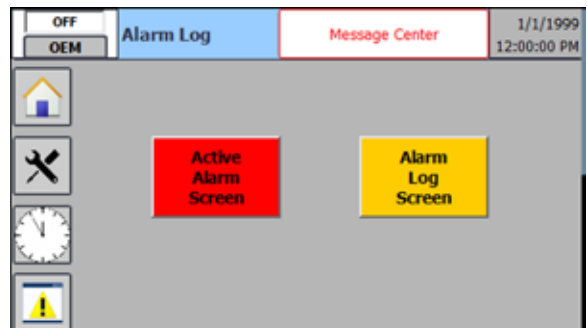



Alarm Codes		
ID	Message	Description
1	Emergency Stop	The emergency stop is active. Rotate the E-stop button counterclockwise to release the button.
2	High Differential Pressure	The differential pressure has exceeded the setpoint and a cleaning cycle has been initiated.
3	Low Brush Speed	The brush speed is below the setpoint. A concentrate purge cycle has been initiated.
4	High DP/Low Brush Attempts Exceeded	Cleaning cycles and purge cycles have not successfully restored performance after several attempts. The filter housing may need to be manually serviced.
5	DP Event Maximum Exceeded	The number of DP-driven cleaning cycles has exceeded the setpoint. There are multiple solutions; see troubleshooting.
6	Low Feed Pressure	The feed pressure is below the setpoint. Inspect pump inlet, valves and possible line fouling.
7	High Feed Pressure	The feed pressure is above the setpoint. Inspect the feed pump and its pressure control system.
8	Feed Tank Low	The feed tank sensor is open. If not empty, check for broken wires.
9	Feed Pump Fault	If so equipped, the feed pump is reporting a fault.
10	Recirculation Pump Fault	The recirculation pump VFD is reporting a fault. Inspect the VFD.
11	Purge Valve 1 Fault	If so equipped with feedback, the valve is reporting a position fault.
12	Purge Valve 2 Fault†	If so equipped with feedback, the valve is reporting a position fault.
13	Purge Valve 3 Fault†	If so equipped with feedback, the valve is reporting a position fault.
14	Air Bleed Valve Fault	If so equipped with feedback, the valve is reporting a position fault.
15	Filtrate Valve Fault	If so equipped with feedback, the valve is reporting a position fault.
16	Filtrate Tank High	The filtrate tank sensor is open. The system will shut down to permit the tank to catch up and drain.

† No longer available on C-series skids



# 4. Operation

## 4.1 Startup

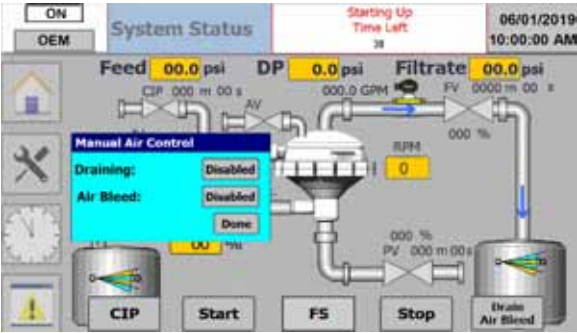

### Notes:

- Refer to “[System Setup](#)” on page 28 for configuring the system for a new system or a process change to an existing system.
- This procedure is based on a typical pressure controlled feed pump. Other setups may require slight alterations.
- For proper operation of the SC-150 skid, it is important that there be no air within the system. Each time the system is started, the air should be bled from the system.

1. Inspect the system to ensure it is ready to start:
  - Make sure the controller is powered, but in the standby state.
  - Make sure that all downstream processes and drains are prepared to receive water.
  - Make sure all upstream processes are active or in standby, and prepared to deliver water.
2. Make sure all valves are closed; filtrate valve, purge valves, inlet valve, service valves, etc.
3. Open the air and high pressure bleed valves. Make sure all downstream valves from the bleed valve (if any) are open. (Note that the main service drain valve is upstream from the air bleed tubing, and it must remain closed.)
4. Ideally, the skid should be gravity bled with low pressure (2-4 psi feed) by allowing water to flow through inactive feed pumps. If the feed water supply is below the skid and the feed pump must power bleed, care must be taken to reduce any pressure surges and water hammers.
5. Touch the AV icon on the home screen. If using gravity to bleed the system then press the Air Bleed button
 
6. Slowly open the feedwater inlet valve just enough to permit a small amount of water into the system to expel air through the air bleed tubing.
7. Continue bleeding the system until no more air is present at the air bleed, and then close the air and high pressure bleed valves.
8. If power bleeding, release the feed pump Manual On button and press the Done button to clear the pop-up screen.
9. Make sure the feedwater service valve is fully open.
10. If the Home screen is not displayed, press the Home icon.
 
11. Press the Start button and confirm (Yes) to begin the startup event.
12. During the startup event, air must be bled from the low-pressure line. After the system has met the minimum RPM setpoint, open the low-pressure bleed valve for a short time until all air is bled.
  - NOTE: this will bleed air on the “clean” side of the filter so adequate cleaning assembly RPM must be confirmed before opening this valve. Failure to do so will cause premature plugging of the filter.

13. On the display, check the feed pressure, differential pressure, and brush speed to ensure the system is operating normally.
14. Observe the filtrate valve position and ensure it reaches the open % setpoint or is tracking the differential pressure setpoint.

## 4.2 Shutdown

The system has 3 shutdown modes; standard shutdown, alarm shutdown, and emergency shutdown.

- Standard shutdown is triggered through the HMI or a network input. The system will shutdown in the best possible way by performing a cleaning cycle, purging the concentrate, and closing all valves before stopping the pumps. Password is required.
- Alarm shutdown is triggered by alarms or faults in the system. It will shutdown in the quickest possible safe method by closing all valves and then stopping the pumps.
- The emergency shutdown is triggered by the emergency stop signal. The system will immediately stop all pumps and close all valves. This will open the opportunity for damage to the filter and should only be used in actual emergencies.

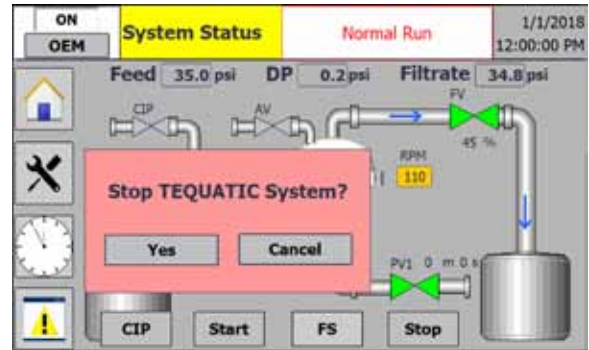

## 4.3 Long-term Shutdown

If the system is being shut down for an extended period of time (over 24 hours), it is best to drain the system.

1. Press the Stop button on the Home screen to shut down the controller. Wait for the system to completely stop.
2. Close the feedwater valve and concentrate return valve.
3. Open the air bleed valve to permit air to enter the filter housing.
4. Open the valve at the bottom of the recirculation pump.



**Note:** If this valve is left open after draining the system, it is a good idea to tag the valve so it is not forgotten when the system is later restarted.

5. Open the service drain valve.
6. Allow the system to fully drain.
7. Power down the controller.
8. For very long-term storage beyond 7 days additional steps must be taken.
  - The filter and cleaning assembly must be removed, cleaned, and stored in a dry location.
  - Flush the skid and filter housing with clean water to purge all settled solids.
  - O-rings must be cleaned and lubricated.
  - Valves must be cycled to ensure solid build up has not solidified on the valve faces.
  - Any areas isolated from normal drainage must be disassembled and drained of water.

## 4.4 System Setup

The following sections describe each of the areas of system setup. Even though many of the parameters are independent, they are presented in sequence based on interdependencies of a complete system setup.

The target of the system setup is to establish a stable differential pressure while reaching the desired flow rate from the system. A stable differential pressure is a reading that does not increase over time. Fluctuations of 0.2 psi is common during operation but a steadily climbing value must be avoided. Setup should be done during periods of especially bad feed water. Conservative settings will ensure the system can be left to run independently as slugs of particles flow into the system.

### 4.4.1 Feedwater Pressure

The feedwater pressure is externally set and controlled by the customer-supplied feed pump and VFD (w/PID) with pressure sensor. The feedwater pressure is primarily facility dependant, and has limited impact on the filtration system operation. However, changing the feedwater pressure during operation will impact the performance of the unit. Therefore, the feedwater pressure should be set before adjusting the rest of the system. A typical pressure may be in the range of 20 - 40 psi, but can vary up to 80 psi, based on the external needs of the facility. Feed pressure cannot drop below 20 psi or cavitation will occur inside housing causing damage. The pressure must remain constant ( $\pm 3$ psi) as the flow requirements change from 0 GPM to 400 GPM over 20 seconds. Large fluctuations in feed pressure will result in water hammers that will damage the filter over time

### 4.4.2 Baseline Brush Speed

The speed of the recirculation pump is set based on the Cleaning Assembly RPM with no filtrate flow. Therefore, the brush speed will be slightly lower than the normal operating speed when filtrate is flowing. The target brush speed is primarily determined by quality of the feedwater; where higher solids concentrations should have higher brush speeds. Typical Cleaning Assembly speeds may be in the range of 80 - 100 rpm.

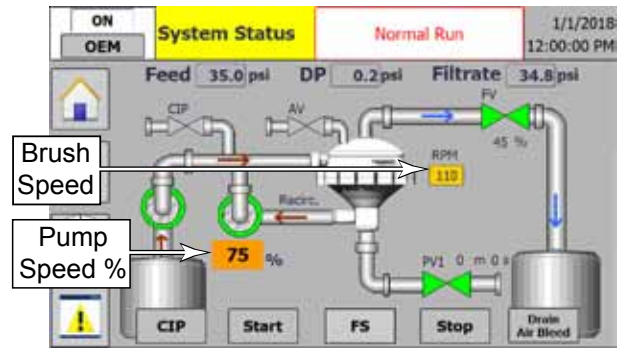

1. Touch the icon for the Recirculation Pump to manually start the pump.
2. Observe the brush speed shown on the Home screen.
  - While making the adjustment, keep in mind that the magnitude of the filtrate flow will increase the operating brush speed, accordingly.
  - Higher removal rates of solids may be achieved through higher brush speeds.
  - Too high of a brush speed can result in excessive wear and energy consumption. Too low of a brush speed can result in more frequent DP events and fouling of the filter.
  - The cleaning assembly speed should be set to maintain stable DP in the very short run interval of 0-5 minutes. If DP value begins to climb uncontrollably during this time frame the RPM must be increased or the brush configuration must be made more aggressive by adding brushes.
3. To adjust the speed of the recirculation pump, enter the RPM screen and set the VFD speed %.

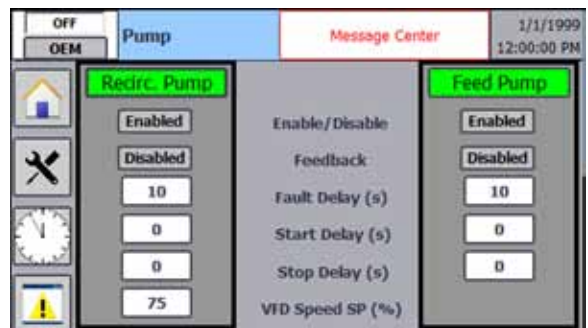

4. Wait for the system to normalize and stabilize, and check the brush speed again.

- Note: During the CIP cycle, the recirculation pump speed can be adjusted to a higher setting.

#### 4.4.3 Filtrate Flow Rate

The filtrate flow rate is controlled by filtrate proportional valve. The valve will open partially to let water out of the system. The open percentage of the valve can be controlled using either PID loops or by manually setting the open percentage. A standard skid can utilize a PID loop to target a DP value allowing maximum possible flow and adjusting as the feedwater particle concentrations fluctuate. With the installation of a flow meter, the skid can target a desired flow rate adjusting as necessary.

- The DP target for the PID control loop should be set relatively low. Setting this value too high will result in excessive flow and result in DP events lowering the efficiency of the filter. For most applications the DP target should remain below 0.8 psid.
- The flow target for the PID loop will open and close the filtrate valve to meet the desired setpoint. This function is especially useful if the facility is also using chemical dosing based on flow rate.
- The manual setting of the filtrate valve will hold it at a specified open percentage letting the flow and DP values fluctuate as the filter condition changes.

The desired result of controlling the flowrate is to allow the filter to run continuously with minimal cleaning cycles. A stable DP value is the best indication that the filter is running within specifications and performing well. These guidelines should be followed to determine the optimal flowrate:

- The stable DP should remain low. It should never exceed 1.2 psid for prolonged operation and most application remain below 0.8 psid.
- Fluctuations in the DP ( $\pm 0.3$  psid) or a steadily climbing DP indicate the flow is set too high and needs to be reduced.
- Frequent DP-triggered cleaning cycles indicate the flow is too high or the brush configuration needs to be more aggressive.
- The filtrate flowrate should be set in conjunction with the cleaning assembly RPM to ensure stable DP in the short 3-8-minute interval. If DP begins to rise uncontrollably the flowrate should be reduced.

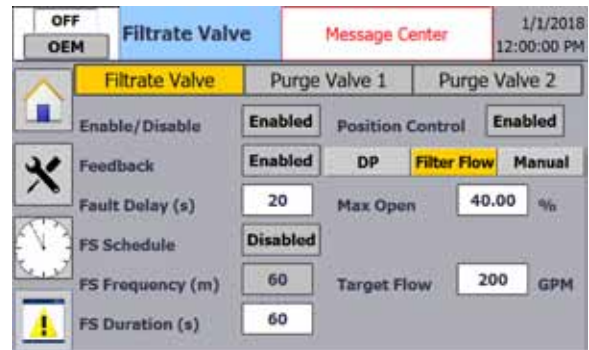

### 4.4.4 Concentrate Purge

The concentrate purge function drains the concentrated solids that tend to accumulate in the lower portion of the filter housing. The two parameters of the concentrate purge are the frequency and duration. Generally, the duration should be long enough to exchange the volume of the lower filter housing with incoming water, but not so long that incoming feedwater is flushed to the drain. The shorter the purge duration, the more concentrated the discharge will be, but if too short, too much concentrate may build up in the system.

The frequency of the purge depends on the degree of solids removal from the feedwater. The more concentrated the feedwater, the more frequent a purge should occur. However, too frequent of a purge rate will reduce the recovery rate with non-concentrated water being discharged. When the purge schedule is disabled the valve can be set to open or closed during run.

The purge events should be set in the medium 5 to 20 minute interval. If the DP rises between purge events and is not fully recovered due to an event, the frequency should be decreased and the duration should be increased.

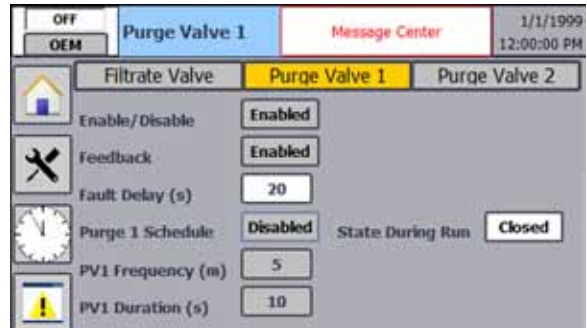

### 4.4.5 Cleaning Cycle Settings

A cleaning cycle is when the filtrate flow is stopped but the brushes continue to rotate against the filter medium. This permits the brushes to more effectively remove particulate from the face of the filter without the pressure differential pushing the particles against the filter. After the opportunity is given to better remove particles they are flushed from the housing using a purge event. Cleaning cycles occur on a timed basis and/or also when the differential pressure exceeds a setpoint.

The settings related to the cleaning cycles are the schedule for timed events, the duration of the event, and the differential pressure setpoint.

Use the “[Valve Settings](#)” described on page 19 to set the frequency of the timed cleaning cycle in minutes (or to disable the timed cleaning cycle) in the Filtrate Valve tab. The frequency of cleaning cycles should be shorter for higher solids water. Too short of a frequency, however, can reduce total throughput, as there is no filtrate flow during a cleaning cycle. (A setting of 60 minutes is a good starting point.)

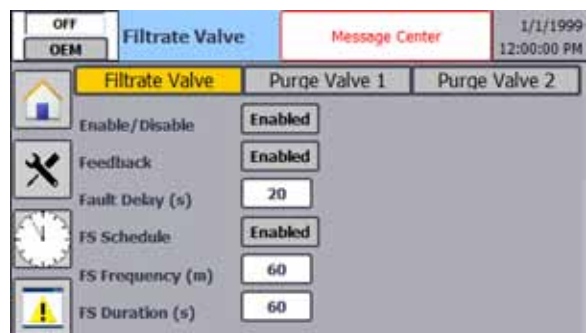

The duration should be long enough to clean the filter, but not so long that the system remains idle after the filter has been cleaned. The more frequent a cleaning cycle occurs, the shorter each cycle may need to last in order to be effective. One possible indication that the duration is set too short is when DP-triggered cleaning cycles occur more frequently than of 45-60 seconds is a good starting range.

Use the “[DP/Pressure Settings](#)” described on page 21 to set the threshold for a DP-triggered cleaning cycle. The “High DP” setting determines the differential pressure value at which a cleaning cycle will be triggered. This can be used in one of two ways: It can be considered as a backup to scheduled cleaning, just in case the filter got



fouled sooner than expected; or the system could be set up to be DP-driven. For a DP-driven system, the DP threshold would be set low, such that DP-triggered cleanings occur before the filter truly fouls. This would be desired for systems with relatively clean water, or if the concentration of solids is significantly varying over time. For this type of system setup, the timed cleaning cycle should be either set very long or disabled.

#### 4.4.6 Clean In Place (CIP)

The Clean In Place (CIP) allows enhanced cleaning for especially difficult process water. A single CIP Event contains one or more CIP cycles.

The CIP should be used when the standard cleaning capabilities of the skid are not adequate to keep the filter clean and running stable. Process waters with high levels of fats, oils, and grease are known to benefit significantly from the addition of CIP. For unknown process waters, a good rule of thumb is the 6-hour time window. If standard skid cleaning tuning allows stable run for over 6 hours before DP issues and filter inspection shows particle buildup, the CIP is a good option. The event will scrub the screen multiple times with addition of cleaning solution and/or warm clean water.

The CIP setting screen provides all setpoints associated with the event. Below is an explanation of how to setup a CIP Event to be as effective as possible.

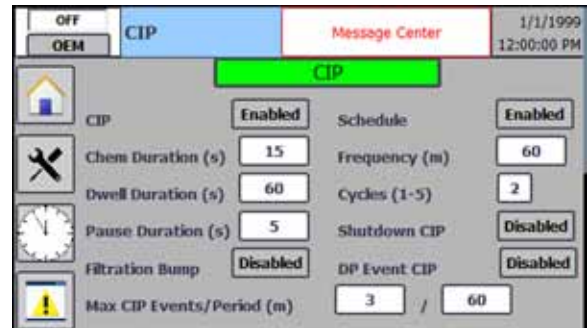

1. Enable CIP once all physical components are installed, parts are available through CFT.
2. Set the duration of Chemical pump “on” time. This can be set at 0 if no chemicals will be used. Only use enough chemicals to clean the filter.
3. Set the Dwell time. This is the time the system will circulate the clean water and chemicals. This setting should be at least 60s for cleaning.
4. Set Pause duration. This is the pause between CIP cycles within a CIP Event and should be in the 10-30s range.
5. Select if a filtrate bump will be used. A filtrate bump will quickly open and close the filtrate valve to allow some of the cleaning water and chemicals inside the filter. Use this if buildup is occurring inside the filter after the water passes through the filter membrane.
6. Enable the Schedule to trigger CIP Events regularly based on the Frequency timer. This should be enabled if the process water has fats, oils, and grease that builds over time.
7. Frequency is the amount of time between triggered CIP Events. A good starting point is 120 minutes. If the filter tends to clog between CIP Events, reduce the timer. If the DP values do not rise between Events lengthen the timer.
8. Set the number of CIP cycles that will occur within a CIP Event. Two cycles are a good starting point. Keep the number of cycles as low as possible. If a CIP Event does not fully clean the filter increase the number of cycles.
9. Shutdown CIP will trigger a CIP Event during a shutdown. This is ideal if the system will be off for an extended period of time.
10. The CIP can be triggered due to the schedule timer or by a technician at the home screen. The Max CIP Events/Period will limit how often they can be triggered to keep chemical usage down.
11. The CIP Drain Valve setting can be adjusted to allow more or less of a Hot Water to into system during the chemical injection step. See the Valves screen Purge CIP Open % setting

## 4.5 SCADA Integration

Networking is performed using the Scalance communication switch and two types of communication are supported, Profinet and Siemens Industrial Ethernet. To communicate to a non-native SCADA a gateway is needed to translate the messages. Each skid must be treated as a slave unit accepting commands from the SCADA and allowing sampling of the software variables.

The network integration is intended to only allow start and stop control of the system while monitoring important variables and alarms. A start or stop command must be a momentary signal, on for a short time and then back off. If the signal is continuous the system will not run properly. Below are the tags provided in a non-optimized data block.

Virtual Tags			
Variable	Data Format	Address	Comments
Start_Command	Bool	db99.dbx0.0	Momentary
Stop_Command	Bool	db99.dbx0.1	Momentary
Skid_off	Bool	db99.dbx2.0	
Skid_off_waiting	Bool	db99.dbx2.1	
Skid_starting	Bool	db99.dbx2.2	
Skid_running	Bool	db99.dbx2.3	
Skid_stopping	Bool	db99.dbx2.4	
Skid_in_CIP	Bool	db99.dbx2.5	
Skid_SD_CIP	Bool	db99.dbx2.6	
Skid_cancelling_CIP	Bool	db99.dbx2.7	
Skid_in_purge	Bool	db99.dbx3.0	
Skid_in_FS	Bool	db99.dbx3.1	
FV_closed	Bool	db99.dbx3.2	
PV_opened	Bool	db99.dbx3.3	
Pump_Speed	real	db99.dbd4	0-100%
RPM	DInt	db99.dbd8	
Feed_Pressure	real	db99.dbd12	
DP_Pressure	real	db99.dbd16	
Alarm_Word1	word	db99.dbw20	
Alarm_Word2	word	db99.dbw22	



Alarm Descriptions				
ID	Name	Alarm text [en-US], Alarm text	Trigger Tag	Bit
1	Discrete_alarm_1	Emergency Stop	Alarm_Word1	8
2	Discrete_alarm_3	High Differential Pressure (1st)	Alarm_Word1	9
3	Discrete_alarm_4	Low Brush Speed	Alarm_Word1	10
4	Discrete_alarm_5	High DP/Low Brush Attempts exceeded	Alarm_Word1	11
5	Discrete_alarm_6	DP Event Maximum exceeded	Alarm_Word1	12
6	Discrete_alarm_7	Low Feed Pressure	Alarm_Word1	13
7	Discrete_alarm_8	High Feed Pressure	Alarm_Word1	14
8	Discrete_alarm_9	Feed Tank Low	Alarm_Word1	15
9	Discrete_alarm_2	Feed Pump Fault	Alarm_Word1	0
10	Discrete_alarm_11	Recirculation Pump Fault	Alarm_Word1	1
11	Discrete_alarm_12	Purge Valve 1 Fault	Alarm_Word1	2
12	Discrete_alarm_13	Purge Valve 2 Fault	Alarm_Word1	3
13	Discrete_alarm_14	Purge Valve 3 Fault	Alarm_Word1	4
14	Discrete_alarm_15	Air Bleed Valve Fault	Alarm_Word1	5
15	Discrete_alarm_16	Filtrate Valve Fault	Alarm_Word1	6
16	Discrete_alarm_17	Filtrate Tank High	Alarm_Word1	7
17	Discrete_alarm_10	High Differential Pressure (2nd)	Alarm_Word2	8
18	Discrete_alarm_18	High Differential Pressure (3nd)	Alarm_Word2	9
19	Discrete_alarm_19	Max CIP Event/Period Reached	Alarm_Word2	10

Hard Outputs				
Address	Symbol	Description	Signal	Note
Q0.0	SQ1	Spare Relay	24 VAC	Relay
Q0.1	OPEN	Open Relay	24 VAC	Relay
Q0.2	SQ2	Spare Relay	24 VAC	Relay
Q0.3	FE	Feed Pump Enable Relay	24 VAC	Relay
Q0.4	EXA	External Alarm	24 VAC	Relay
Q0.5	AV	Air Valve	24 VAC	External Encl.
Q0.6	HV	Clean In Place Hot Valve	24 VAC	External Encl.
Q0.7	IV	Feed Inlet Valve Relay	24 VAC	External Encl.
Q1.0	CP	Clean In Place Chemical Pump	24 VAC	External Encl.
Q1.1	OPEN	Spare Valve	24 VAC	External Encl.

<b>Hard Inputs</b>				
<b>Address</b>	<b>Symbols</b>	<b>Description</b>	<b>Signal</b>	<b>Note</b>
I0.0	FS	Flow Sensor	24 VDC	Fused 500 mA CB
I0.1	LS-P	Product Tank High	24 VDC	Fused 500 mA CB
I0.2	LS-F	Feed Tank Low	24 VDC	Fused 500 mA CB
I0.3	SPARE	Spare	24 VDC	Fused 500 mA CB
I0.4	ES	E-Stop	24 VDC	Fused 500 mA CB
I0.5	FP-S	Feed Pump Enabled Status	24 VDC	Fused 500 mA CB
I0.6	SPARE	Spare	24 VDC	Fused 500 mA CB
I0.7	AV-O	Air Valve Status Open	24 VDC	Fused 500 mA CB
I1.0	IV-O	Inlet Valve Status Open	24 VDC	Fused 500 mA CB
I1.1	HV-O	HV Status Closed	24 VDC	Fused 500 mA CB
I1.2	SPARE	Spare	24 VDC	Fused 500 mA CB
I1.3	IC-C	Inlet Valve Status Closed	24 VDC	
I1.4	AV-C	Air Valve Status Closed	24 VDC	
I1.5	SPARE	Spare	24 VDC	
AI 0	PS-H	Pressure Sensor High	0-10V	
AI 1	PS-L	Pressure Sensor Low	0-10V	

# 5. Maintenance

## 5.1 Replacing the Filter or Brushes



**Caution:** To avoid risk of injury, make sure the system is depressurized and drained before loosening the upper filter housing. Take special precautions when handling hazardous or high-temperature fluids. Wear appropriate protective equipment, such as a hard hat, when hoisting the housing.

The filter and brushes don't necessarily need to be replaced at the same time, but the procedure is the same for both.

1. Perform a normal “**Shutdown**” described on page 27.
2. To prevent any unexpected backflow, close all incoming and outgoing valves.
3. Open the maintenance drain valve and the air bleed valve to drain the housing, and allow all water to drain.
4. After making sure there is no pressure left in the system, remove the filtrate, air bleed and feedwater lines between the filter housing and the rest of the system. To open the quick couplers, raise their release lever.

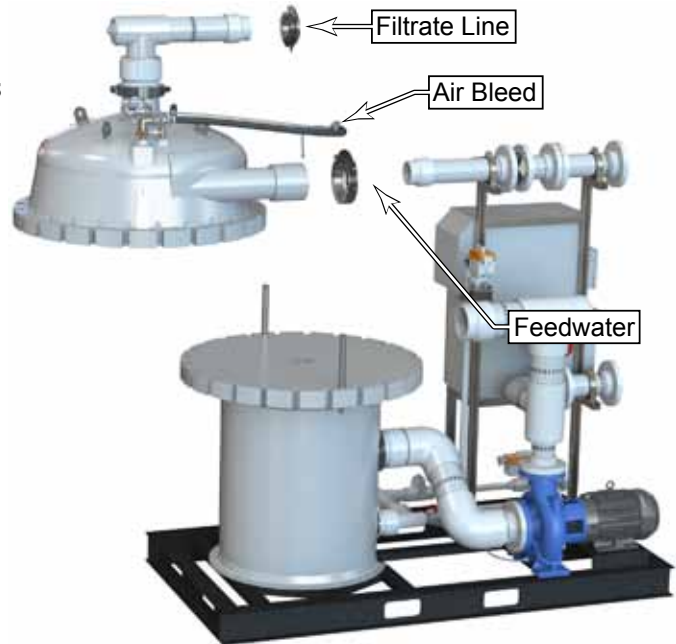

**Notice:** Be careful when working around the filter housing with tools to avoid damaging the housing. Also, take care not to disturb the pressure and speed sensors on the upper filter housing.

5. Disconnect the RPM sensor, two pressure sensors and ground wire connectors.
6. Loosen the 24 swing bolts on the filter housing, and swing them down out of their mounting slots.



7. Secure a 4-point hoisting chain to the four lifting eyes on the top of the filter housing.
8. Lift the upper filter housing straight up until it is clear of the alignment pins, and move it clear of the filter housing.



**Caution:** Use care when lifting or lowering the upper filter housing. The housing is heavy, and also poses pinch-points between the upper and lower surfaces. Be aware of any binding on locating pins.

9. For safety, lower the upper housing on to a non-marring surface, such as wooden cribbing or a pallet. Avoid resting it on the floor, as the mating surface could be damaged.
10. Rotate the top adapter counterclockwise to release it from the filter, and remove the adapter.
  - Note that the filter also rotates counterclockwise, so you may feel two stops before the adapter unlocks from the filter.
  - The filter adapter serves two purposes. It serves as the interface between the center of the filter and the upper housing, and also retains the cleaning assembly to the top of the filter.
11. To remove the cleaning assembly, rotate clockwise (with the grain of the brush bristles) while lifting it off the filter.
  - Inspect the brushes for wear or damage. If many of the bristles are broken, kinked, or missing, replace the cleaning assembly.
12. Rotate the filter approximately 1/8-turn counterclockwise to unlock it from the vortex plate, and remove the filter. (It may have already rotated during top plate and cleaning assembly removal.)
13. (Optional) The water insert/Vortex Plate Assembly doesn't specifically need to be removed for cleaning but if necessary carefully remove the 4 mounting screws from the Vortex Plate and remove the assembly.

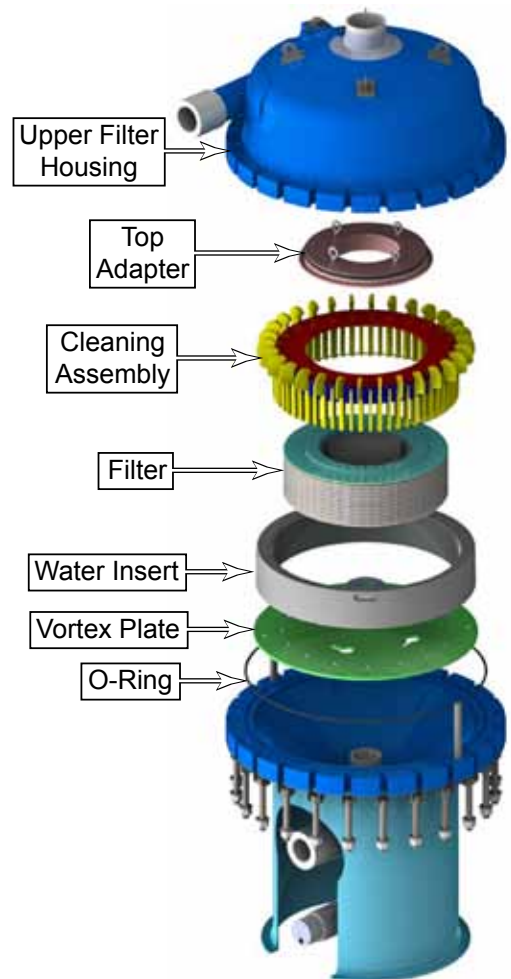
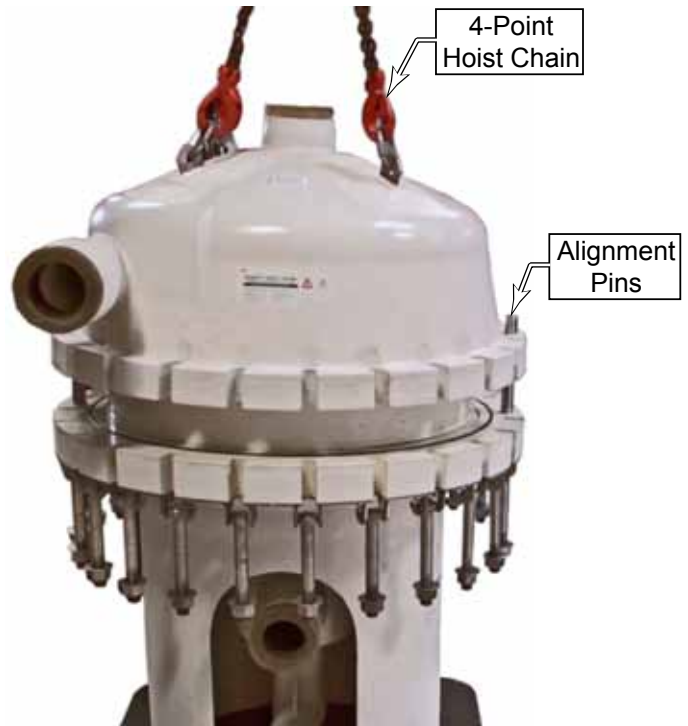

14. (Optional) The vortex plate should not normally be removed unless the lower housing needs to be cleaned. The vortex plate is secured with four screws. If the vortex plate is removed, locate the Vortex key and align with the cutout in the housing to orient it properly in the housing during reassembly.

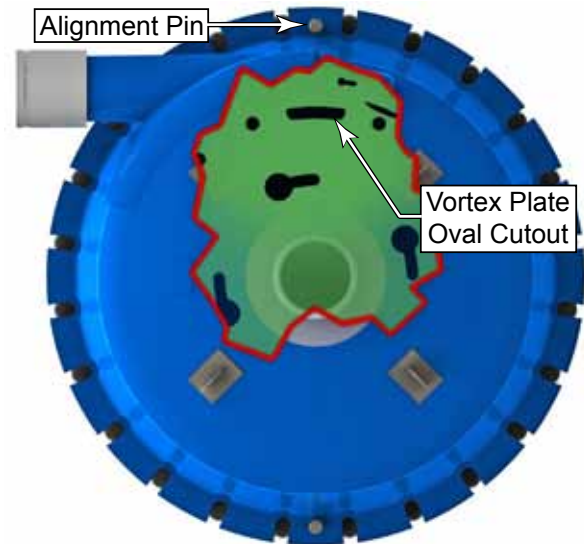

### 5.1.1 Replacement Notes

The reassembly procedure is the reverse of the disassembly with the notations below:

- Thoroughly clean the interior of the filter housing, especially the sealing surfaces, O-ring grooves and O-rings.
- When replacing the filter, position the seam in the filter membrane away from the water inlet.
- Rotate the cleaning assembly clockwise while placing it over the filter. This reduces the bending of the bristles sideways.
- Before installing the filter adapter, clean the interface on the filter and apply a light coat of lubricant to both O-rings to aid the assembly.
- When closing the upper housing, make sure to lower it straight down over the alignment pins. Make sure the main O-ring is seated properly in its groove.
- Torque the mounting bolts to 80 lb-ft (108 N-m) in a crossing pattern.
- Make sure to bleed the system before restarting.

## 5.2 Troubleshooting

The following is a list of common troubleshooting scenarios. Where applicable, inspections and/or resolutions are listed by order of ease of completion or likelihood of occurrence.

Problem	Possible Cause	Solution
Elevated differential pressure	Insufficient cleaning of filter membrane	<ul style="list-style-type: none"> <li>• The frequency and/or duration of the forward spin cycles may be insufficient.</li> <li>• The brushes may be worn and need replacement.</li> <li>• The filter membrane may be worn and need replacement.</li> <li>• The process water may need enhanced cleaning using a CIP kit</li> </ul>
	Excessive filtrate flow	Excessive flow rate can cause an elevated pressure differential. Reduce the flow rate according to system optimization described on <a href="#">page 29</a>
	Process water solids concentration too high	<ul style="list-style-type: none"> <li>• A periodic spike in influent solids may be cleared with an extra cleaning cycle.</li> <li>• Frequent spikes in influent solids may require a larger feed tank to equalize solids loading.</li> <li>• Frequent or steady elevated solids may require a reduction in the filtrate flow rate.</li> <li>• Increase concentrate purge frequency and/or purge duration.</li> </ul>
	Check the speed of the cleaning/brush assembly.	<ul style="list-style-type: none"> <li>• If the brush speed is higher than normal it is an indication that the total flow rate is too high.</li> <li>• Worn or missing brushes can cause the brush speed to be high but not cleaning. Replace the cleaning assembly or brushes.</li> <li>• High velocity water flow (high brush speed) can cause an artificially elevated differential pressure that is not reflective of the actual flow.</li> </ul>
	Pressure sensors may be faulty	<ul style="list-style-type: none"> <li>• Bleed sensor lines then ensure the bleed valves are closed.</li> <li>• Inspect the pressure transmission tubes for leaks, kinks, and air bubbles.</li> <li>• Diagnose and/or replace the sensor.</li> </ul>
Low differential pressure	Insufficient water flow	A low flow rate across the filter will show as a low differential pressure.
	Breach in filter element	Replace filter element.
	Zero reading	<ul style="list-style-type: none"> <li>• Inspect the pressure transmission tubes for leaks, kinks and air bubbles.</li> <li>• Ensure sensor bleed valves are closed</li> <li>• Inspect the sensor wires for an open circuit.</li> <li>• Diagnose and/or replace the sensor.</li> </ul>
Low filtrate flow	No flow	<ul style="list-style-type: none"> <li>• Make sure that all feedwater and filtrate valves that should be open are open.</li> <li>• Make sure that all concentrate and maintenance valves that should be closed are closed.</li> <li>• Inspect filter for wear and clogging</li> </ul>
	Limited flow	<ul style="list-style-type: none"> <li>• Check the filtrate flow diaphragm valve</li> <li>• If the differential pressure is high, inspect the filter for blockage.</li> <li>• If the differential pressure is low, make sure the feed pump (if present) and recirculation pump are functioning.</li> </ul>

Problem	Possible Cause	Solution
Low RPM	Build up on Cleaning Assembly Bearing	<ul style="list-style-type: none"> <li>• Increase purge frequency and duration</li> <li>• Incorporate CIP for enhanced cleaning.</li> </ul>
	Sensor Fault	<ul style="list-style-type: none"> <li>• Ensure sensor is plugged in</li> <li>• Sensor should be touching filter housing.</li> <li>• Check using free magnet and swipe past sensor</li> <li>• Adjust sensor placement on mounting bracket, move up or down until a signal is read.</li> <li>• Ensure the cleaning assembly still has a magnet installed.</li> </ul>
	Recirculation pump not running	<ul style="list-style-type: none"> <li>• With unit fully powered down, check that the pump will spin freely.</li> <li>• Inspect wiring at the VFD and the pump for an open or bridged circuit.</li> </ul>
Recirculation pump is running immediately upon unit power up or not stopping during shutdown.	System not shutdown properly	<ul style="list-style-type: none"> <li>• Check if system has had a recent power loss.</li> <li>• Use E-Stop to stop the running pumps; log into the HMI using appropriate credentials; select the “Stop” button and confirm the pop-up to stop the unit; release the E-Stop button and ensure the pumps do not run. If they continue to run repeat the process.</li> <li>• Cycle the system power and ensure fully de-powered for 10 minutes before power up.</li> </ul>
	Network communication not correct	<ul style="list-style-type: none"> <li>• Set network connection to “none” and re-attempt shutdown.</li> <li>• Ensure SCADA is sending momentary signals to unit.</li> </ul>
System stuck in a particular sequence and not able to move on.	Valve feedback has not been received	<ul style="list-style-type: none"> <li>• Check the feedback wires to ensure the connections are still made</li> <li>• Confirm the valve has reached the end of its travel, if it is binding it must be freed to complete travel.</li> <li>• Manually cycle the valve full travel using the HMI, this will reset the position in the control system.</li> </ul>
	A required set point has not been reached	<ul style="list-style-type: none"> <li>• Ensure enough time has been given that any timers have been completed</li> <li>• Ensure the RPM or DP setpoints are not set beyond what the system is capable of, reduce these values if necessary.</li> </ul>
Valve indication reverse valve actual position.	Feedback is reversed and/ or does not match PLC valve location.	<ul style="list-style-type: none"> <li>• Ensure valve plugs and connections are correct.</li> <li>• Check wiring inside valve housing</li> <li>• Manually cycle valve from HMI, valve must make full travel cycle.</li> <li>• Cycle power and ensure fully de-powered for 10 minutes before power up.</li> </ul>
Excessive noise from filter	Air in system	<ul style="list-style-type: none"> <li>• Vent air from system.</li> <li>• Low feed pressure can cause cavitation. Make sure the feed pressure is above 20 psi.</li> </ul>
	Cleaning assembly making contact with housing or filter	<ul style="list-style-type: none"> <li>• Verify that cleaning assembly is installed correctly.</li> <li>• Inspect the cleaning assembly for broken paddles.</li> </ul>

## 6. Spare Parts

6.1 Filter Housing Components				
Item	Amiad <sup>1</sup>	RSQ <sup>2</sup>	Qty	Description
1	X	1	1	O-ring, Seal, Filter Adapter
2	X		1	Top Adapter
3	X		1	O-ring, Seal, Filter
4	X	1	1	Cleaning Assembly
5	X	1	30	Individual Brush
6	X	1	1	SSC-17-1, Filter, 80-240 gpm (18.2-54.5 m <sup>3</sup> /hr)
				SSC-22-1, Filter, 120-280 gpm (27.3-63.6 m <sup>3</sup> /hr)
				SSC-27-1, Filter, 160-320 gpm (36.3-72.7 m <sup>3</sup> /hr)
7	X		1	Water Insert & Vortex Plate
8	X	1	1	O-ring, Seal, Main Housing
9	X		24	Swing Bolt

1 Orderable through Amiad Water Systems

2 Recommended Spare Quantity



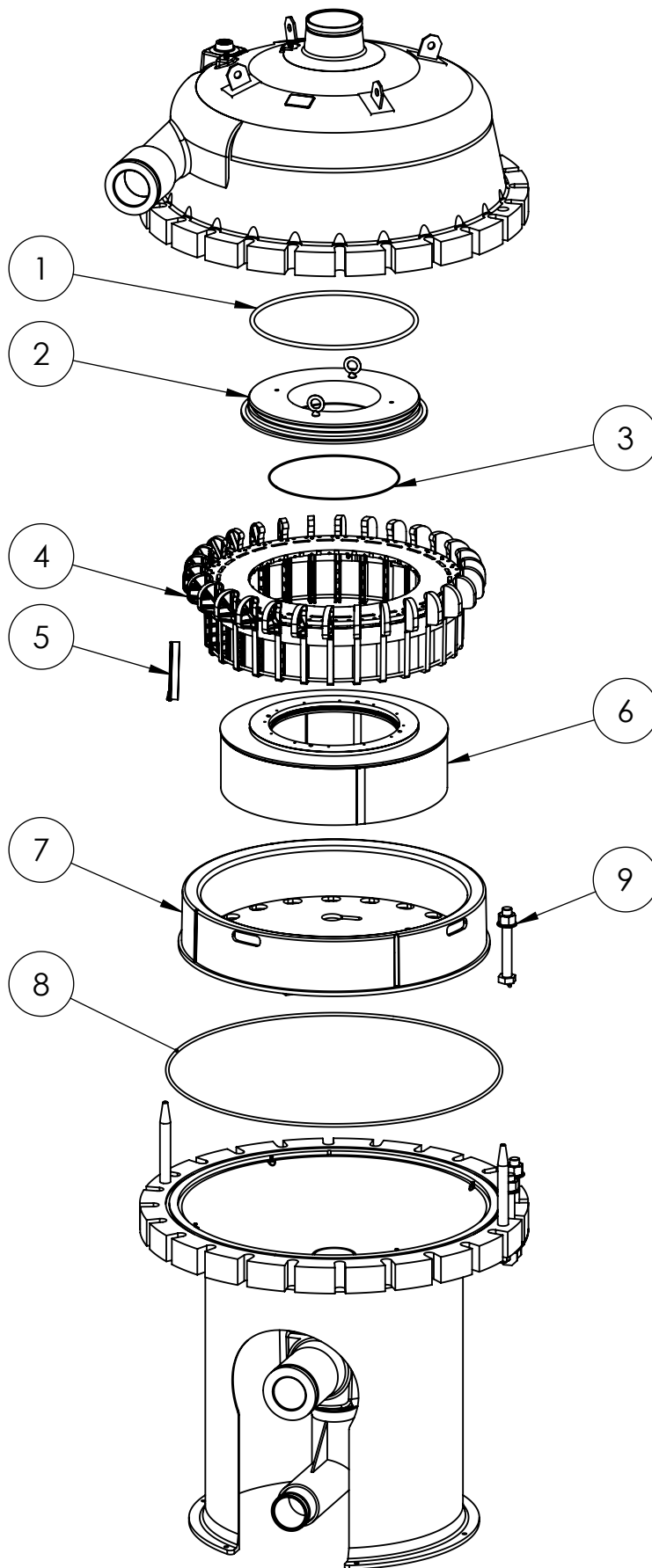

6.2 Plumbing Components					
Item	Amiad <sup>1</sup>	RSQ <sup>2</sup>	Qty	Name	Source, Part Number
1			1	Ball Valve, 1.00" Actuated	Georg Fischer 150.104.335
2			1	Ball Valve, 1.00" Socket	Georg Fischer 163.546.354
3	X		1	Bracket, Rpm Sensor	Amiad
4			1	Butterfly Valve, 2.5" Wafer, Type 145 Actuated	Georg Fischer 150.145.305
5			1	Butterfly Valve, 2.5" Wafer, Type 145 Proportional	Georg Fischer S150.145.305 W/199.190.603
6			1	Camlock, 1.0" Plug X 1.0" Mnpt	Bee Valve 100f-F
7			1	Flange Gasket, 2.5",	Viton 2
8			1	Flange Gasket, 5.00",	Viton 1
9			2	Grooved Pipe Coupler, 4.00" Pipe	Shurjoint 4 G28 Galv O Gask
10			3	Grooved Pipe Coupler, 6.00" Pipe	Shurjoint 6 G28 Galv O Gask
11			2	Pipe Hanger, 1.00" Pipe, Vib Damp	Hydra-Zorb 200100-4-655
12			3	Pipe Hanger, 2.00" Pipe, Vib Damp	Hydra-Zorb 200200-4-655
13			3	Pipe Hanger, 2.5" Pipe, Vib Damp	Hydra-Zorb 200250-4-665
14			—	—	
15			2	Pressure Sensor, 0-100psi Range, 0-10v Signal,	Wika 52728681
16			1	Pump, 5 X 4 Flg X 7.25 Imp, 10hp 1750 Rpm	
17	X		1	Rpm Sensor, Pnp Type,	Sensor Solutions S12-EPPHS-P5SB10-03
18	X		1	Sc-Univ, Check Valve, 2"	Amiad
19	X		1	Sc-Univ, Check Valve, 2.5"	Amiad
20			1	Valve, Vacuum Relief, 0,75 Mnpt	Watts Lfn36-M1-3/4
21			1	Ball Valve, 1.00" Actuated	Georg Fischer 150.104.335

1 Orderable through Amiad Water Systems

2 Recommended Spare Quantity

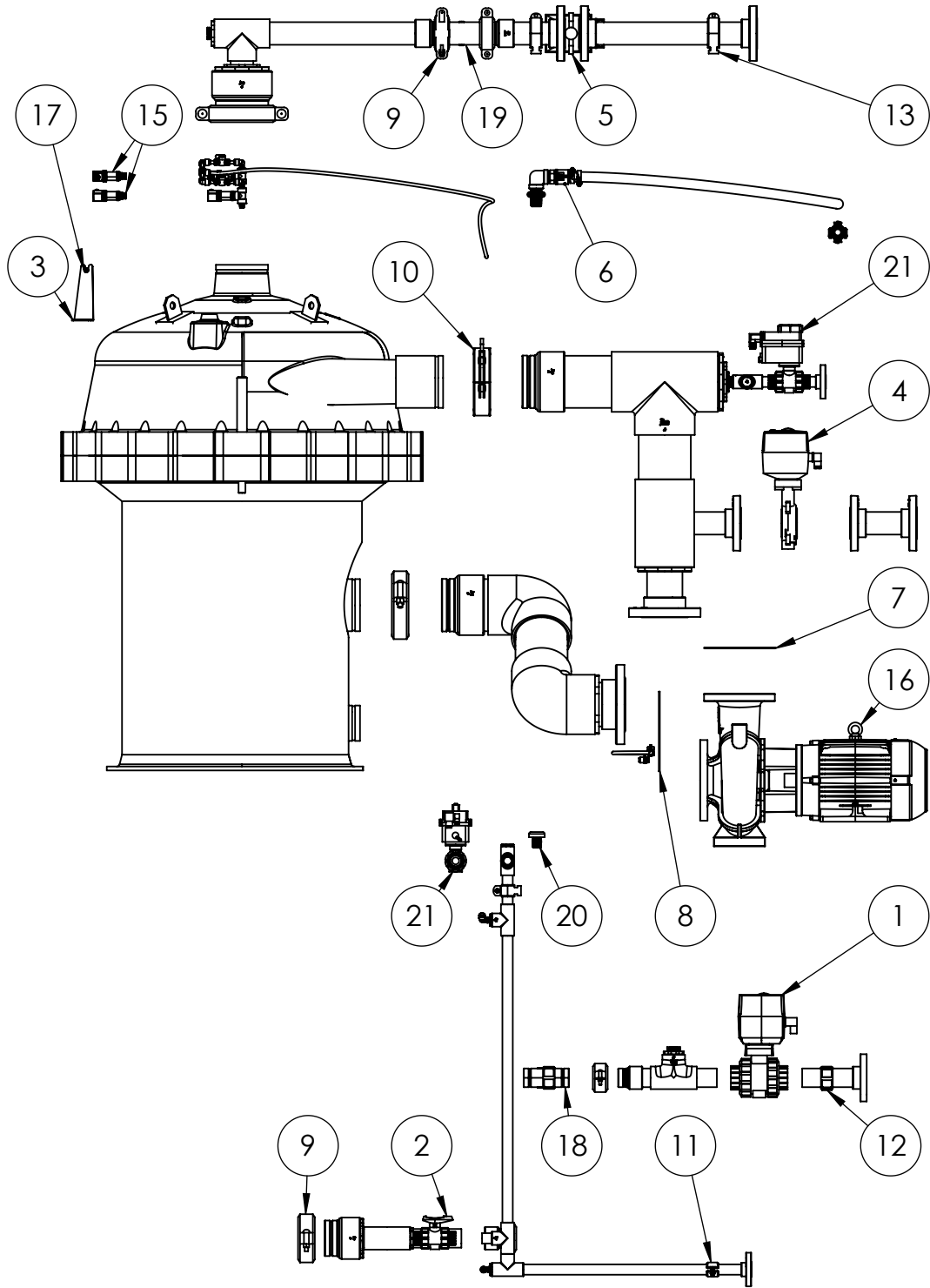

6.3 Controller Components					
Item	Amiad <sup>1</sup>	RSQ <sup>2</sup>	Qty	Description	Source
1			1	Hmi Display	Siemens; 6AV2124-0GC01-0AX0
2			1	Main Breaker (25A)	Siemens; 3VA5125-4ED31-0AA0
3			1	Main Breaker (Handle)	Siemens; 3VA9137-0FK31
4			19	Terminal Block (3 Tier)	Weidmueller; 1784180000
5			22	Terminal Block (2 Tier)	Weidmueller; 1021500000
6			5	Relay, Spdt	Weidmueller; Relay: 4060120000 + Socket: 1123250000
7			6	Relay, Dpdt	Weidmueller; Relay: 4058570000 + Socket: 1123990000
8			1	Power Supply (Logic)	Siemens; 6EP1333-3BA10
9			1	Power Supply (Valves)	Siemens; 6EP1334-3BA10
10			1	Circuit Breaker (1A)	Siemens; 5SJ4201-7HG42
11			1	Circuit Breaker (2A)	Siemens; 5SJ4202-7HG43
12			1	Circuit Breaker (5A)	Siemens; 5SJ4111-8HG41
13			1	Circuit Breaker (10A)	Siemens; 5SJ4110-8HG42
14			1	Overload, Vfd (Set 23A)	Siemens; 3RV2021-4DA10
15			1	PLC	Siemens; 6ES7214-1AG40-0XB0
16			1	Analog Module	Siemens; 6ES7234-4HE32-0XB0
17			1	Ethernet Switch	Siemens; 6GK-005-0BA00-1AB2
18			1	Signal Conditioner	Weidmueller; 8581180000
			1	Vfd	Siemens; 6SL3210-1PE21-8AL0 + 6SL3244-0BB12-1FA0
			1	Thermostat	PFANNENBERG; 17121000010

1 Orderable through Amiad Water Systems

2 Recommended Spare Quantity

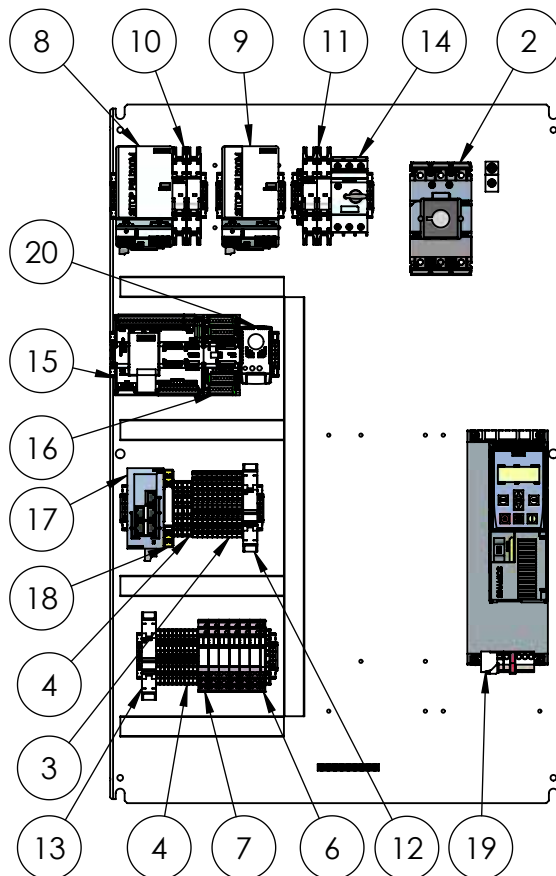
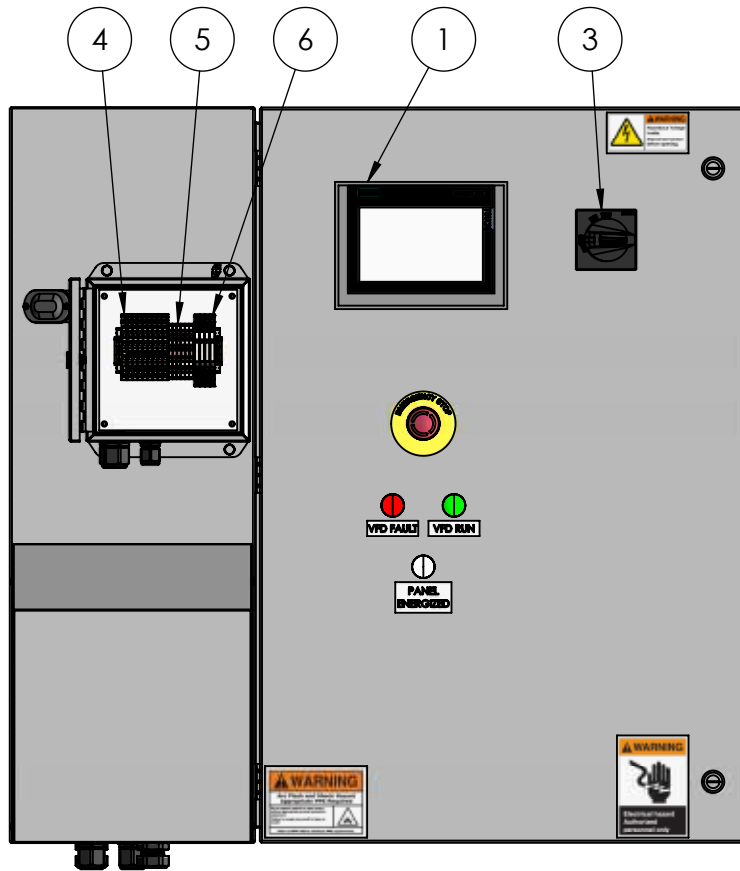

460V 60Hz 3Ø 25A

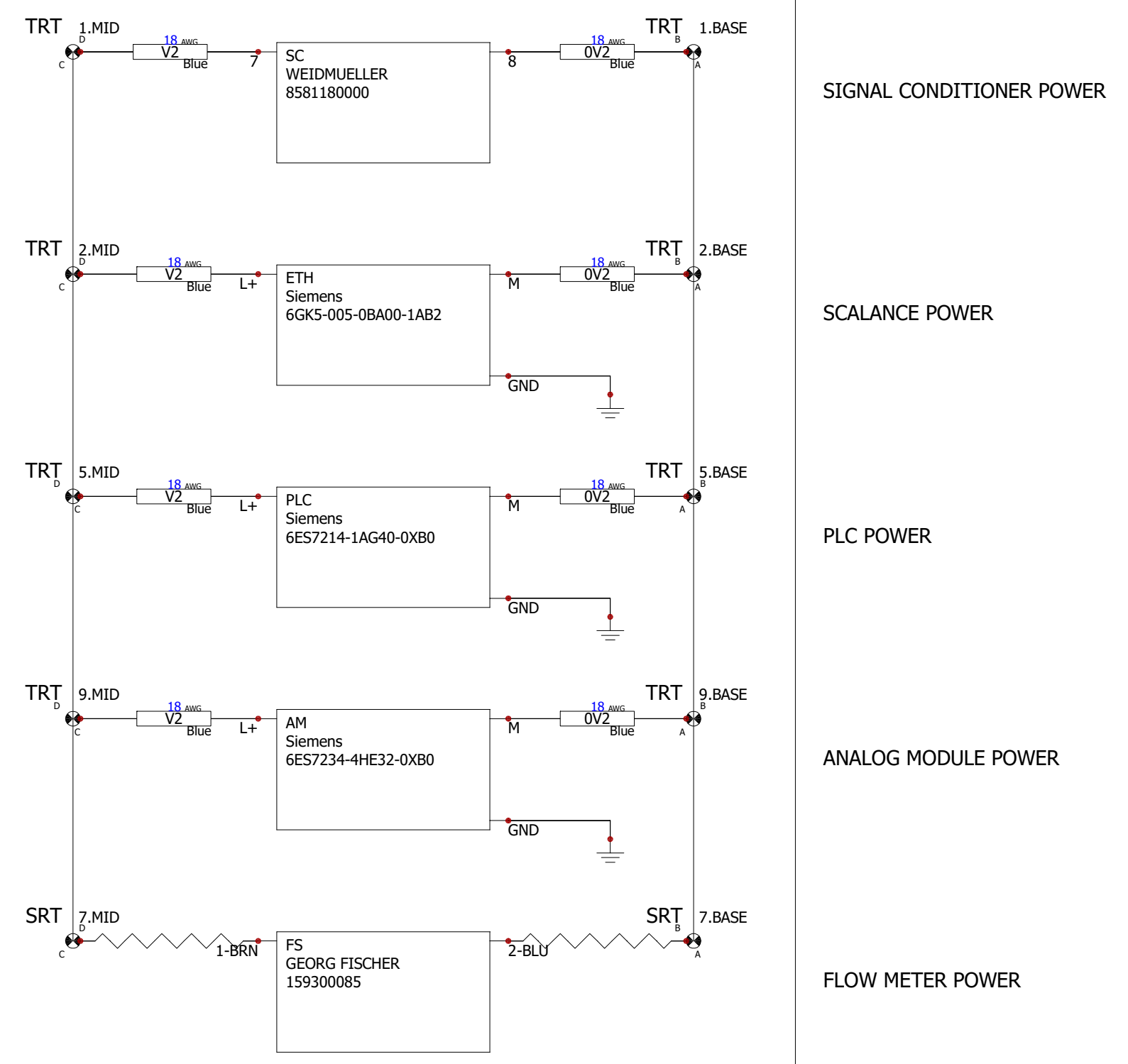
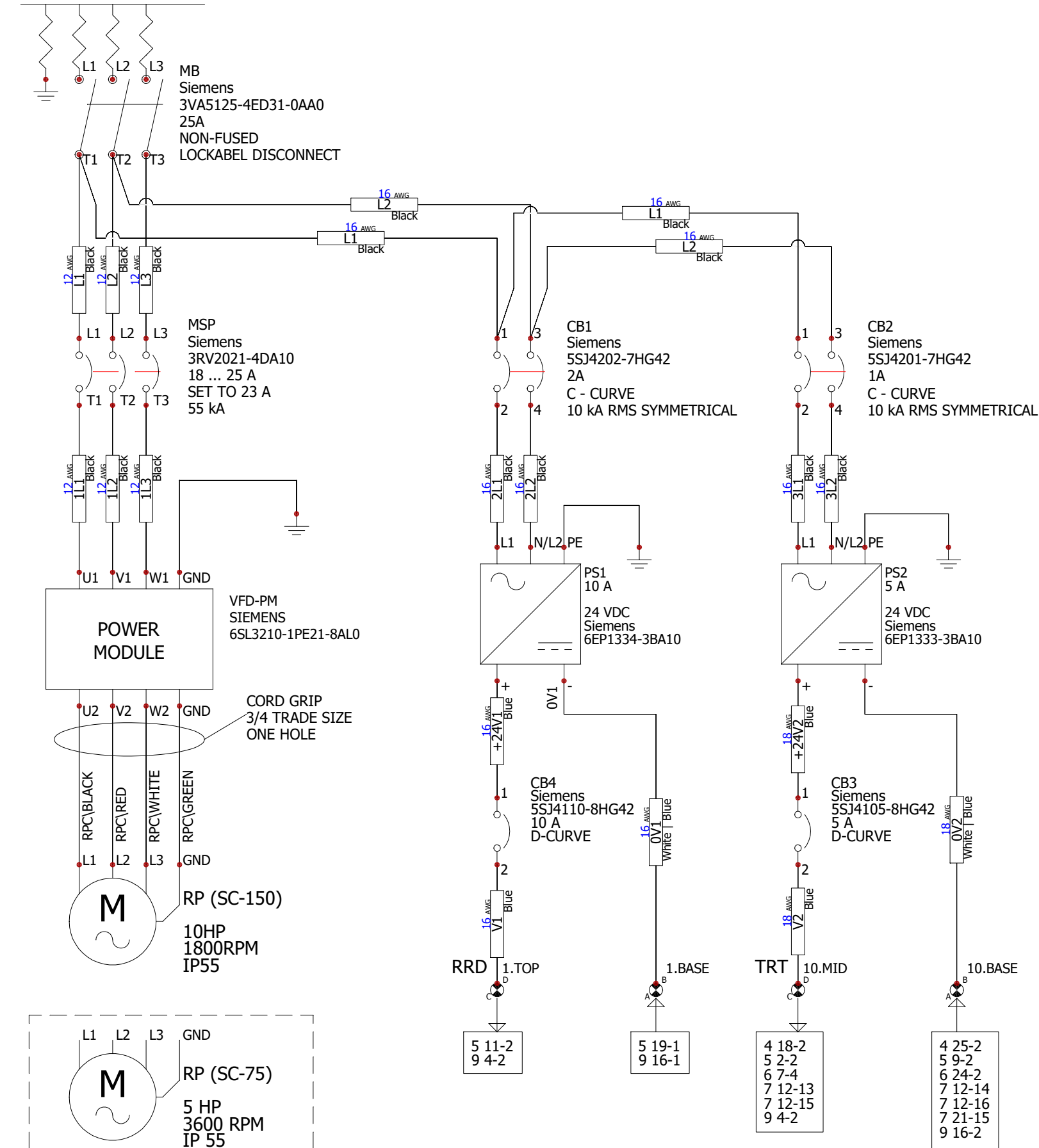

SIGNAL CONDITIONER POWER

SCALANCE POWER

PLC POWER

ANALOG MODULE POWER

FLOW METER POWER

**amiad**®  
WATER SYSTEMS

120-J TALBERT ROAD  
MOORESVILLE, NC 28117 USA  
(800) 648-9260 INFOUSA@AMIAD.COM  
TEQUATIC™ PLUS PRODUCT LINE

THIS DRAWING AND THE INFORMATION CONTAINED HERIN IS THE PROPERTY OF AMIAD WATER SYSTEMS. ANY USE OR REPRODUCTION THEROF WITHOUT THE WRITTEN PERMISSION OF AMIAD WATER SYSTEMS ENGINEERING DEPARTMENT IS STRICLY PROHIBITED. TEQUATIC™ IS A TRADEMARK OF THE DOW CHEMICAL COMPANY (DOW) OR AN AFFILIATED COMPANY OF DOW, USED UNDER LICENSE

DRAWING DATE:		DRAWING TITLE: TEQUATIC™ PLUS C-SERIES SKID PANEL	
SCALE: SHT. 04 OF 10		DRAWING NUMBER:	REV. NO. <b>4</b>
DRAWN BY:		CATALOG NUMBER: 720102-002456	
CHKD BY:		GENERAL TOLERANCES ALL DIMENSIONS IN INCHES (EXCEPT AS NOTED)	ANGULAR ± 1° FRACTIONAL ± 1/8 DEC: 2PL ± 0.05, 3PL ± 0.010
REV.	DATE	NOTES	BY
GENERAL REVISIONS		APP. BY:	

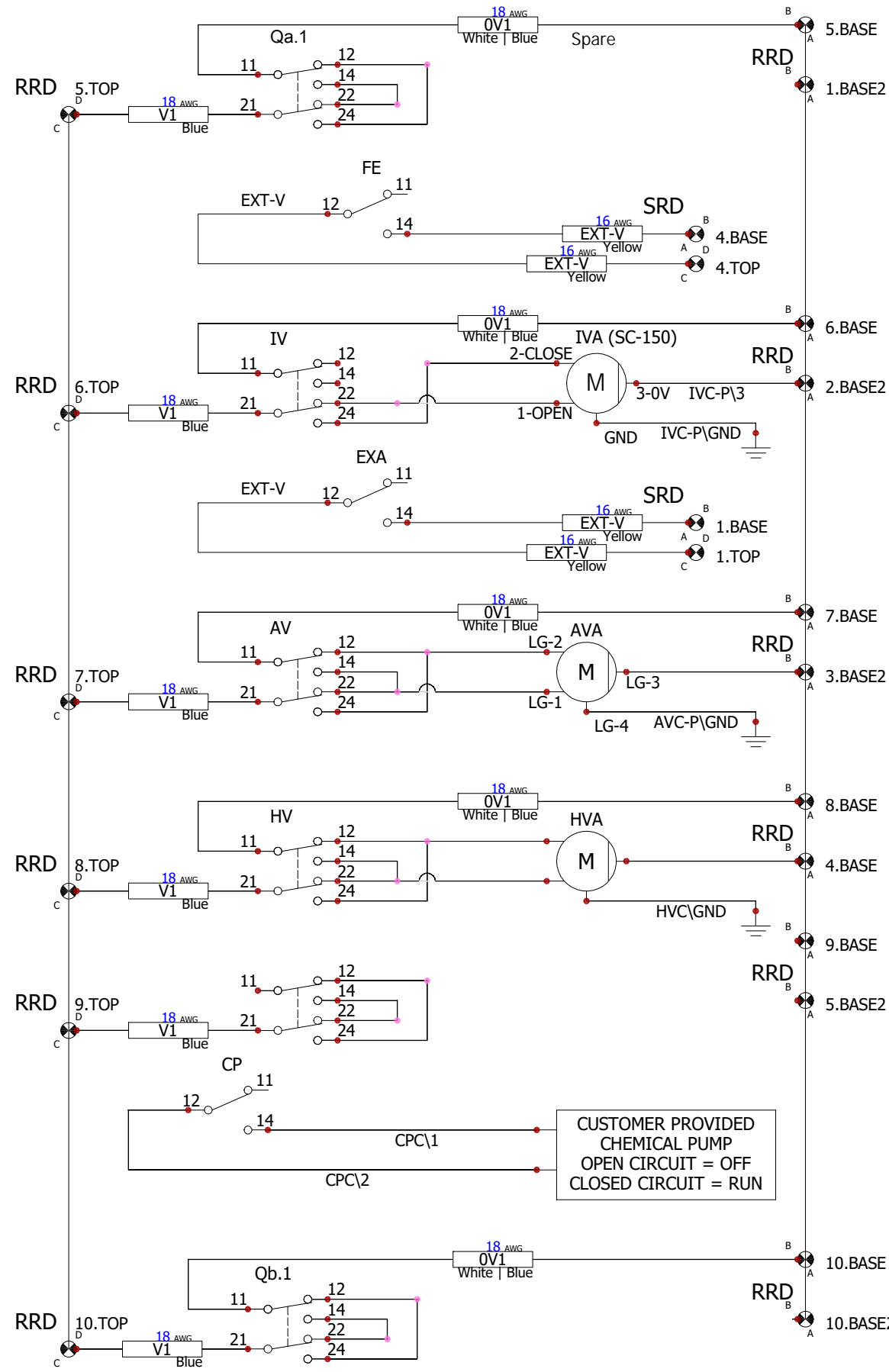
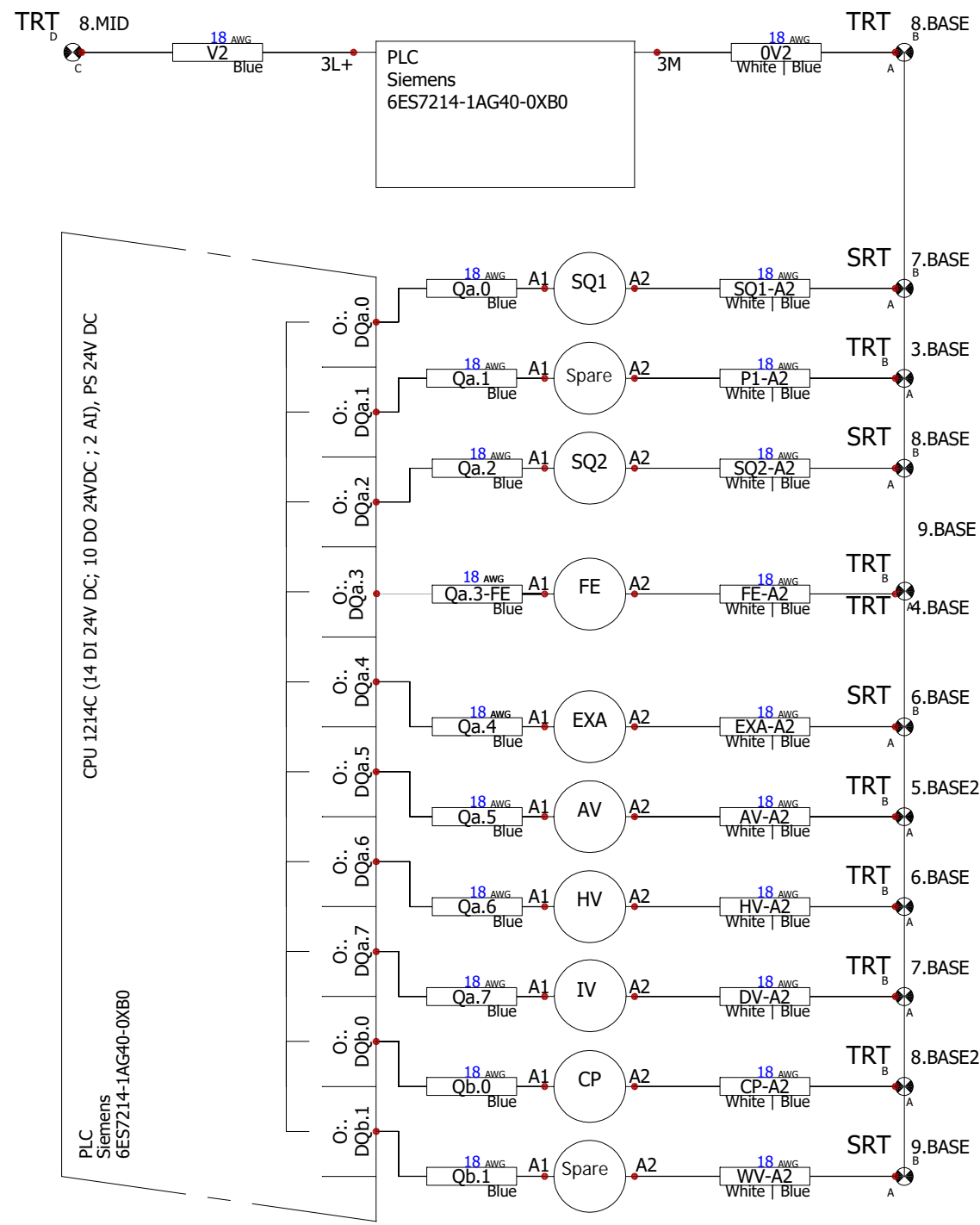

OPEN RELAY

INLET VALVE  
REVERSING ACTUATOR  
ACTIVE RELAY = OPEN VALVE

EXTERNAL ALARM CUSTOMER  
WIRE TO RELAY

AIR VALVE  
REVERSING ACTUATOR  
ACTIVE RELAY = OPEN VALVE

HOT VALVE (CIP)  
REVERSING ACTUATOR  
ACTIVE RELAY = OPEN VALVE

OPEN RELAY

CHEMICAL PUMP ENABLE  
CUSTOMER WIRE TO  
PROVIDED 20' CABLE

OPEN RELAY

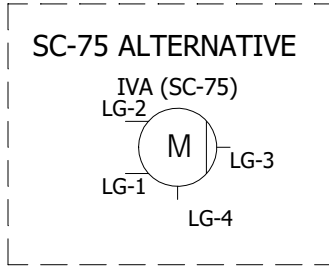

SRT - Terminals in Side Mounted External Box  
SRD - Terminals in Side Mounted External Box



120-J TALBERT ROAD  
MOORESVILLE, NC 28117 USA  
(800) 648-9260 INFOUSA@AMIAD.COM  
TEQUATIC™ PLUS PRODUCT LINE

THIS DRAWING AND THE INFORMATION CONTAINED HERIN IS THE PROPERTY OF AMIAD WATER SYSTEMS. ANY USE OR REPRODUCTION THEREOF WITHOUT THE WRITTEN PERMISSION OF AMIAD WATER SYSTEMS ENGINEERING DEPARTMENT IS STRICTLY PROHIBITED. TEQUATIC™ IS A TRADEMARK OF THE DOW CHEMICAL COMPANY (DOW) OR AN AFFILIATED COMPANY OF DOW, USED UNDER LICENSE.

DRAWING DATE:		DRAWING TITLE:	
SCALE:		TEQUATIC™ PLUS C-SERIES SKID PANEL	
SHT. 05 OF 10		DRAWING NUMBER:	
DRAWN BY:		REV. NO. 4	
CHKD BY:		RELAYS	
APP. BY:		CATALOG NUMBER: 720102-002456	
GENERAL TOLERANCES ALL DIMENSIONS IN INCHES (EXCEPT AS NOTED)		ANGULAR ± 1° FRACTIONAL ± 1/8 DEC: 2PL ± 0.05, 3PL ± 0.010	
REV.	DATE	NOTES	BY
GENERAL REVISIONS			

1  
2  
3  
4 FLOW SENSOR PULSE INPUT  
5 LEVEL SWITCH - PRODUCT TANK, LOGIC SELECTABLE  
6 LEVEL SWITCH - FEED TANK, LOGIC SELECTABLE  
7 SPARE INPUT  
8 STOP, CUSTOMER REMOVE BRIDGE TO TIE IN  
9 EXTERNAL VFD STATUS CLOSED = CONFIRMED RUN  
10 SPARE INPUT  
11 AIR VALVE OPEN  
12 SPARE INPUT  
13 HOT VALVE CLOSED  
14 INLET VALVE STATUS OPEN  
15 INLET VALVE STATUS CLOSED  
16 AIR VALVE STATUS CLOSED  
17 SPARE INPUT  
18

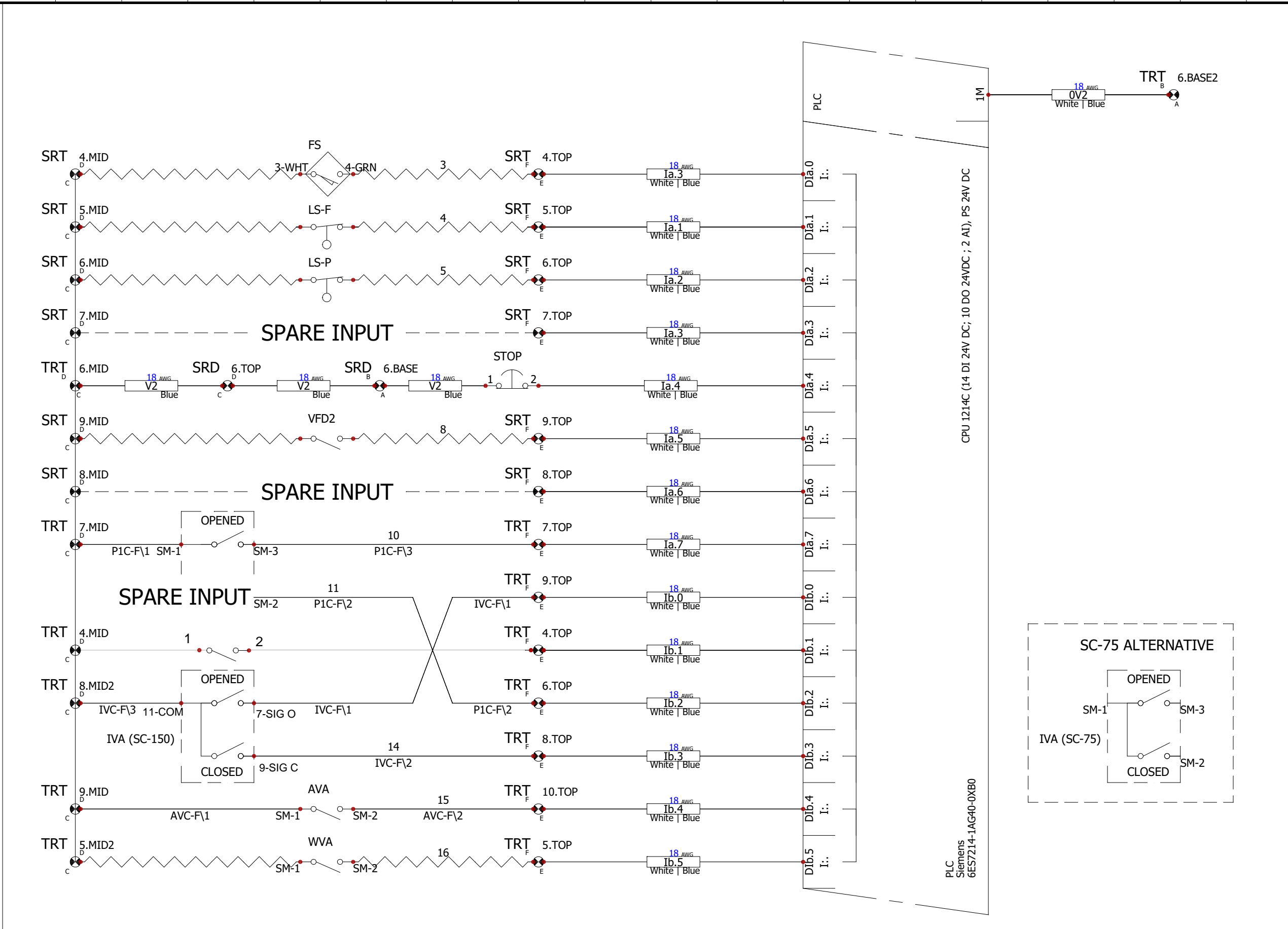

SRT - Terminals in Side Mounted External Box  
SRD - Terminals in Side Mounted External Box

**amiad**<sup>®</sup> WATER SYSTEMS  
120-J TALBERT ROAD  
MOORESVILLE, NC 28117 USA  
(800) 648-9260 INFOUSA@AMIAD.COM  
TEQUATIC™ PLUS PRODUCT LINE

THIS DRAWING AND THE INFORMATION CONTAINED HERIN IS THE PROPERTY OF AMIAD WATER SYSTEMS. ANY USE OR REPRODUCTION THEREOF WITHOUT THE WRITTEN PERMISSION OF AMIAD WATER SYSTEMS ENGINEERING DEPARTMENT IS STRICTLY PROHIBITED. TEQUATIC™ IS A TRADEMARK OF THE DOW CHEMICAL COMPANY (DOW) OR AN AFFILIATED COMPANY OF DOW, USED UNDER LICENSE.

DRAWING DATE:		DRAWING TITLE:	
SCALE:		TEQUATIC™ PLUS C-SERIES SKID PANEL	
SHT. 06 OF 10		DRAWING NUMBER:	REV. NO. 4
DRAWN BY:		DIGITAL INPUT	
CHKD BY:		CATALOG NUMBER: 720102-002456	
APP. BY:		GENERAL TOLERANCES ALL DIMENSIONS IN INCHES (EXCEPT AS NOTED)	ANGULAR ± 1° FRACTIONAL ± 1/8 DEC: 2PL ± 0.05, 3PL ± 0.010
REV.	DATE	NOTES	BY
GENERAL REVISIONS			



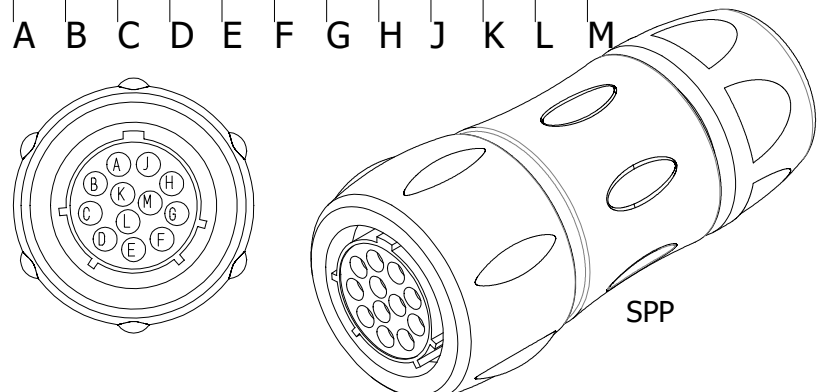
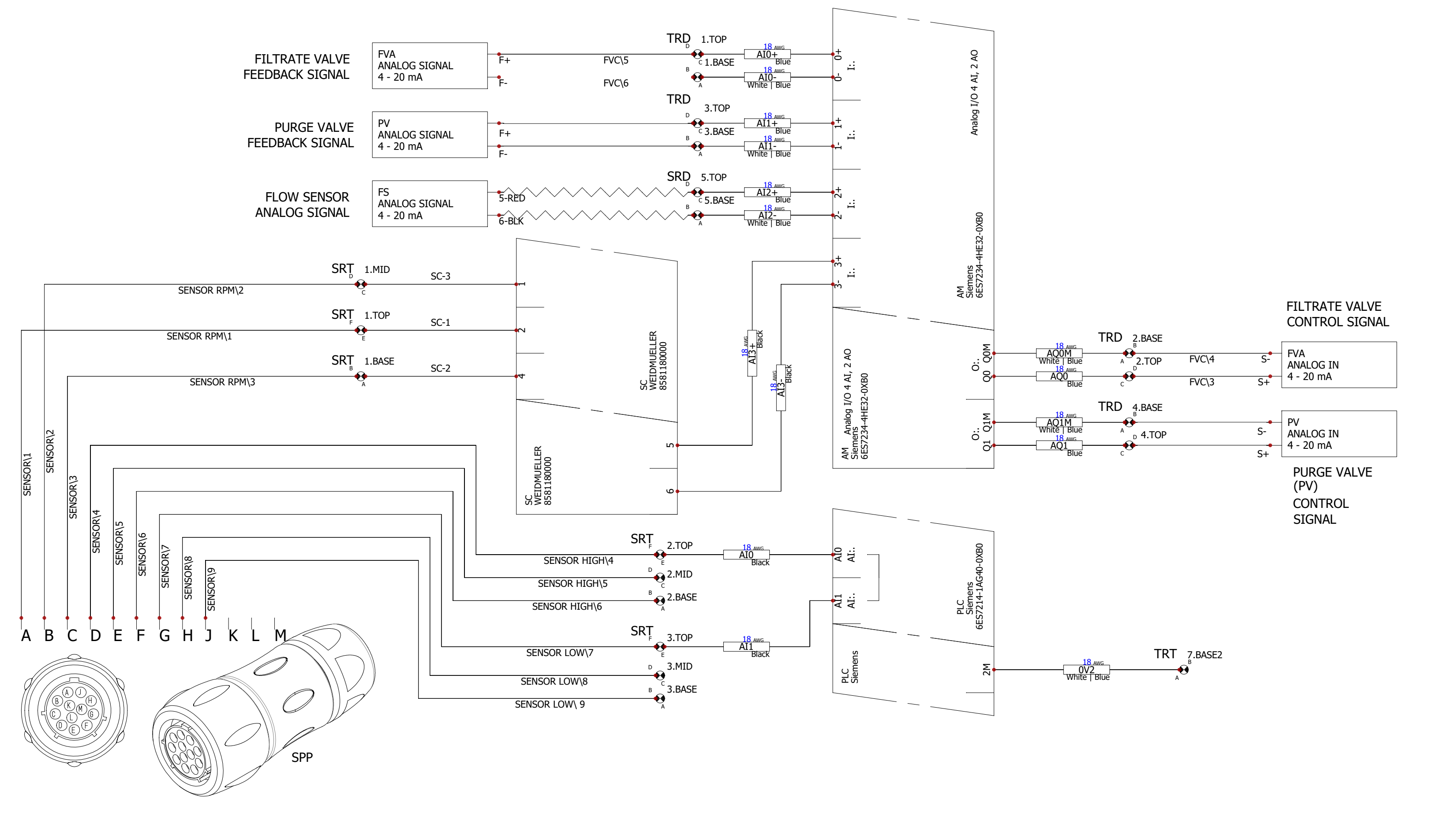

**amiad**<sup>®</sup> WATER SYSTEMS  
 120-J TALBERT ROAD  
 MOORESVILLE, NC 28117 USA  
 (800) 648-9260 INFOUSA@AMIAD.COM  
 TEQUATIC™ PLUS PRODUCT LINE

THIS DRAWING AND THE INFORMATION CONTAINED HERIN IS THE PROPERTY OF AMIAD WATER SYSTEMS. ANY USE OR REPRODUCTION THEREOF WITHOUT THE WRITTEN PERMISSION OF AMIAD WATER SYSTEMS ENGINEERING DEPARTMENT IS STRICTLY PROHIBITED. TEQUATIC™ IS A TRADEMARK OF THE DOW CHEMICAL COMPANY (DOW) OR AN AFFILIATED COMPANY OF DOW, USED UNDER LICENSE.

			DRAWING DATE:		DRAWING TITLE:	
					TEQUATIC™ PLUS C-SERIES SKID PANEL	
			SCALE:		DRAWING NUMBER:	
			SHT. 07 OF 10		ANALOG	
			DRAWN BY:		CATALOG NUMBER: 720102-002456	
			CHKD BY:		GENERAL TOLERANCES	
			APP. BY:		ALL DIMENSIONS IN INCHES	
					ANGULAR ± 1°	
					FRACTIONAL ± 1/8	
					DEC: 2PL ± 0.05, 3PL ± 0.010	

REV.	DATE	NOTES	BY	CHKD BY:
GENERAL REVISIONS				

PRESSURE SENSOR  
LOW (FILTRATE) SIDE  
MOUNTED TO HOUSING

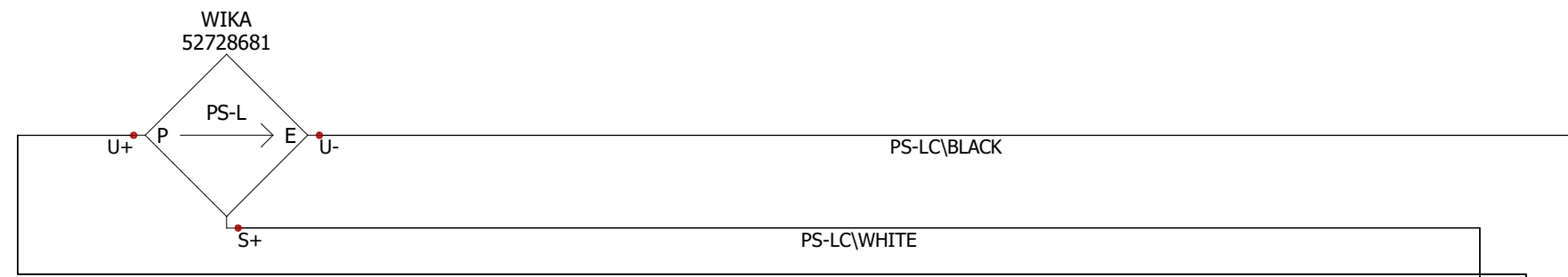

PRESSURE SENOR  
HIGH (FEED) SIDE  
MOUNTED TO HOUSING

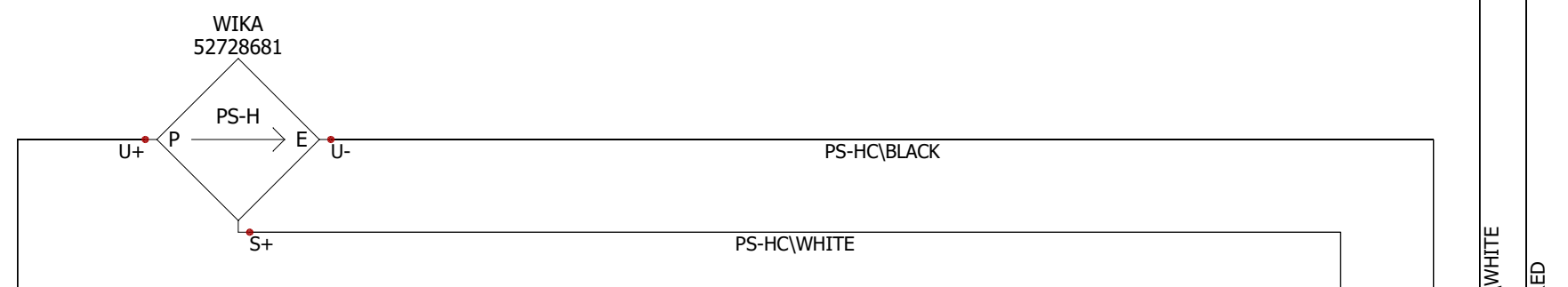

RPM SENSOR  
MOUNTED TO HOUSING

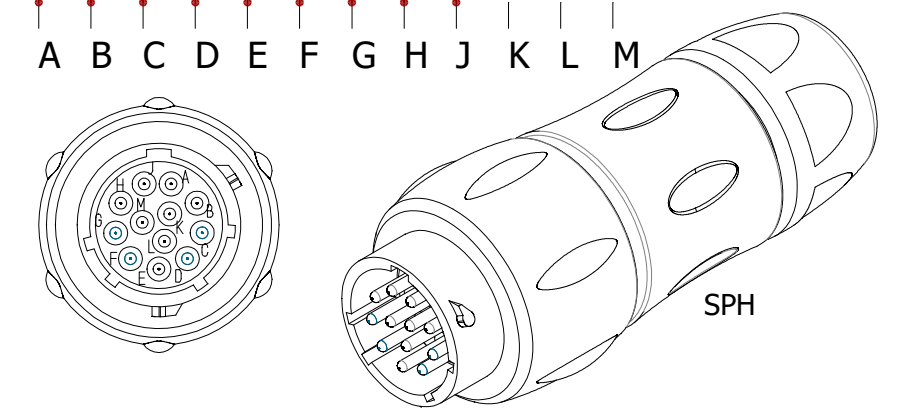
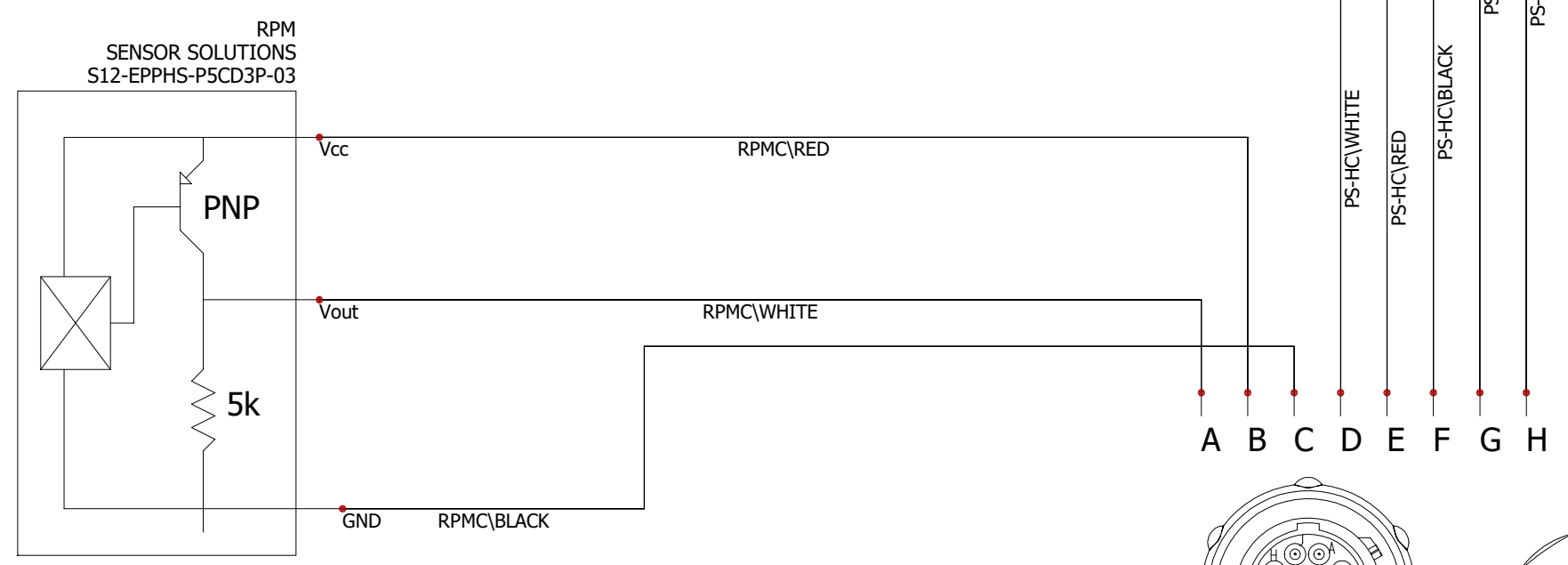

**amiad**<sup>®</sup> WATER SYSTEMS  
 120-J TALBERT ROAD  
 MOORESVILLE, NC 28117 USA  
 (800) 648-9260 INFOUSA@AMIAD.COM  
 TEQUATIC™ PLUS PRODUCT LINE

THIS DRAWING AND THE INFORMATION CONTAINED HERIN IS THE PROPERTY OF AMIAD WATER SYSTEMS. ANY USE OR REPRODUCTION THEREOF WITHOUT THE WRITTEN PERMISSION OF AMIAD WATER SYSTEMS ENGINEERING DEPARTMENT IS STRICTLY PROHIBITED. TEQUATIC™ IS A TRADEMARK OF THE DOW CHEMICAL COMPANY (DOW) OR AN AFFILIATED COMPANY OF DOW, USED UNDER LICENSE.

			DRAWING DATE:		DRAWING TITLE: TEQUATIC™ PLUS C-SERIES SKID PANEL	
			SCALE: SHT. 08 OF 10		DRAWING NUMBER: SENSORS	
			DRAWN BY:		REV. NO. 4	
			CHKD BY:		CATALOG NUMBER: 720102-002456	
REV. DATE			NOTES		BY	
			APP. BY:		GENERAL TOLERANCES ALL DIMENSIONS IN INCHES (EXCEPT AS NOTED)	
			GENERAL REVISIONS		ANGULAR ± 1° FRACTIONAL ± 1/8 DEC: 2PL ± 0.05, 3PL ± 0.010	

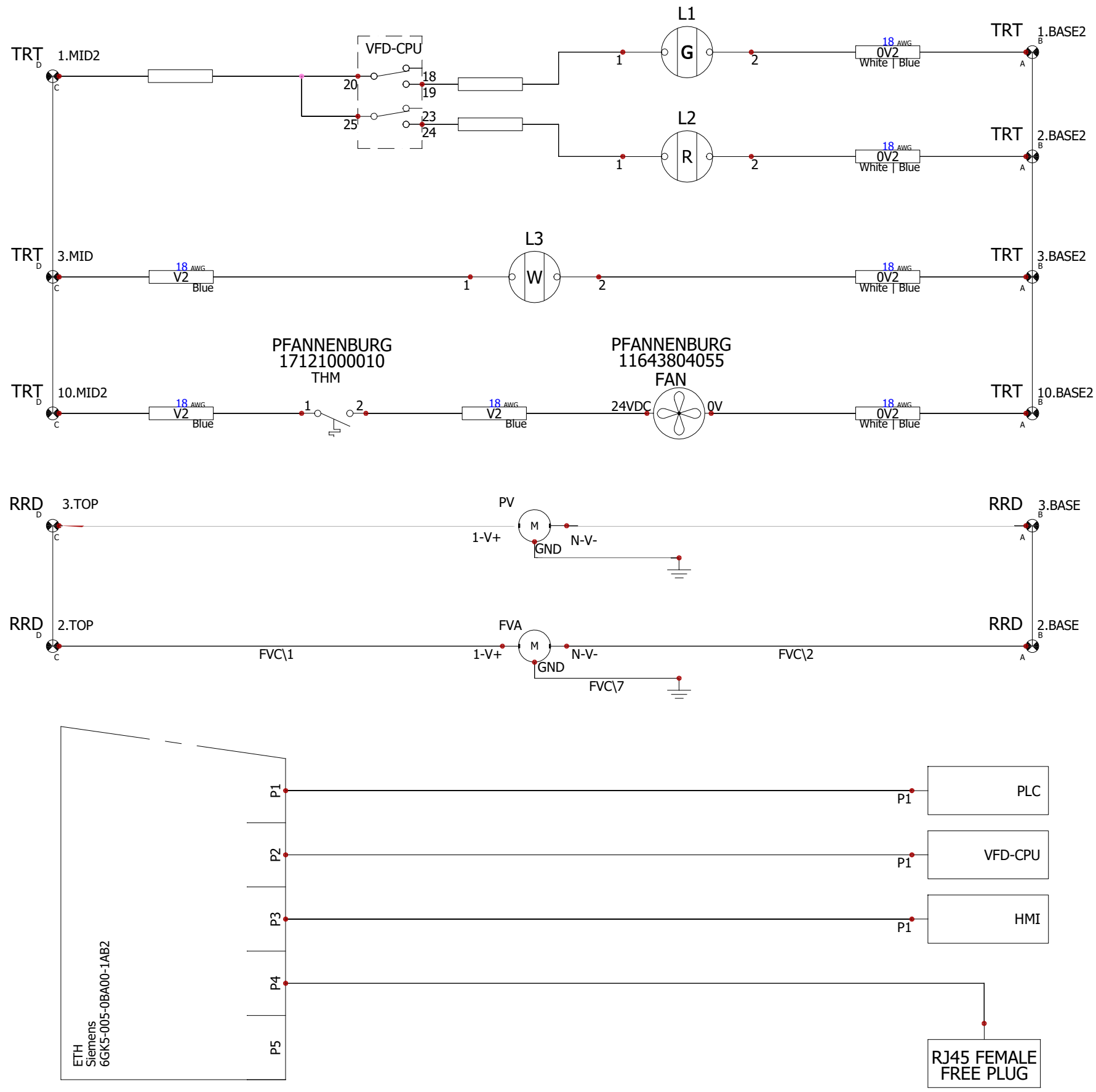

- VFD RUN
- VFD FAULT
- PANEL ENERGIZED
- ENCLOSURE COOLING
- PROPORTIONAL PURGE VALVE MOTOR POWER
- PROPORTIONAL FILTRATE VALVE MOTOR POWER
- ETHERNET TO PLC
- ETHERNET TO VFD
- ETHERNET TO HMI
- FREE ETHERNET FOR SERVICE

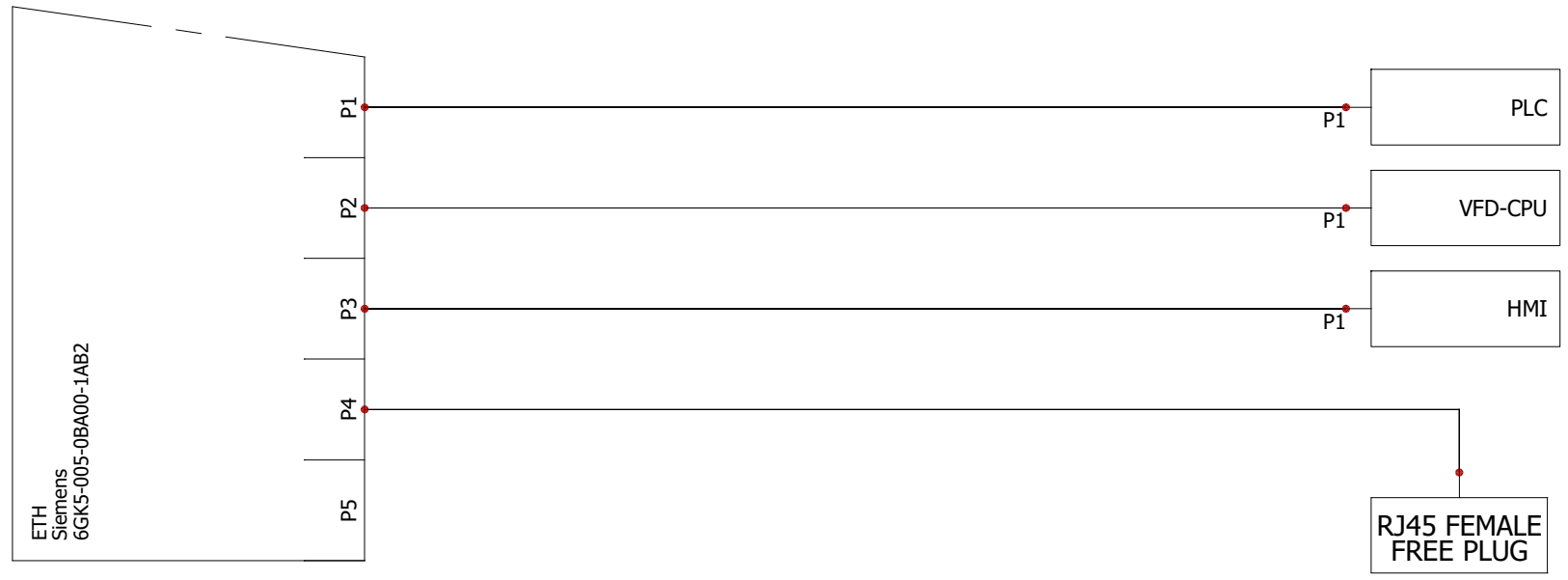

**amiad**<sup>®</sup> WATER SYSTEMS  
 120-J TALBERT ROAD  
 MOORESVILLE, NC 28117 USA  
 (800) 648-9260 INFOUSA@AMIAD.COM  
 TEQUATIC™ PLUS PRODUCT LINE

THIS DRAWING AND THE INFORMATION CONTAINED HERIN IS THE PROPERTY OF AMIAD WATER SYSTEMS. ANY USE OR REPRODUCTION THEREOF WITHOUT THE WRITTEN PERMISSION OF AMIAD WATER SYSTEMS ENGINEERING DEPARTMENT IS STRICTLY PROHIBITED. TEQUATIC™ IS A TRADEMARK OF THE DOW CHEMICAL COMPANY (DOW) OR AN AFFILIATED COMPANY OF DOW, USED UNDER LICENSE.

DRAWING DATE:		DRAWING TITLE:	
SCALE:		TEQUATIC™ PLUS C-SERIES SKID PANEL	
SHT. 09 OF 10		DRAWING NUMBER:	REV. NO. 4
DRAWN BY:		MISC.	
CHKD BY:		CATALOG NUMBER: 720102-002456	
APP. BY:		GENERAL TOLERANCES ALL DIMENSIONS IN INCHES (EXCEPT AS NOTED)	ANGULAR ± 1° FRACTIONAL ± 1/8 DEC: 2PL ± 0.05, 3PL ± 0.010
REV.	DATE	NOTES	BY
GENERAL REVISIONS			

# VFD PARAMETERS

PAR. NO.	NAME	SC-150	SC-75	NOTE
p0010	DRIVE, COMMISSIONING PARAMETER FILTER	1	1	START QUICK COMMISSIONING
p0015	MACRO DRIVE UNIT	12	12	FACTORY SETTING
p0100	IEC/NEMA MOTOR STANDARD	1	1	NEMA MOTOR (60 Hz, US UNITS)
p0205	POWER UNIT APPLICATION	1	1	LOAD DUTY CYCLE WITH LOW OVERLOAD FOR VECTOR DRIVES
p0230	DRIVE FILTER TYPE, MOTOR SIDE	0	0	NO FILTER
p0300	MOTOR TYPE SELECTION	1	1	INDUCTION MOTOR
p0301	MOTOR CODE NUMBER SELECTION	0	0	MOTOR NOT PRE-DEFINED IN VFD
p0304	RATED MOTOR VOLTAGE	460	460	FROM MOTOR NAMEPLATE
p0305	RATED MOTOR CURRENT	12.4	5.9	FROM MOTOR NAMEPLATE
p0306	NUMBER OF MOTORS CONNECTED IN PARALLEL	1	1	VFD RUNS ONE MOTOR
p0307	RATED MOTOR POWER	10	5	FROM MOTOR NAMEPLATE, IN HP
p0308	RATED MOTOR POWER FACTOR	N/A	N/A	NOT AVAILABLE FOR INDUCTION MOTOR
p0309	RATED MOTOR EFFICIENCY	91.7	87.5	FROM MOTOR NAMEPLATE
p0310	RATED MOTOR FREQUENCY	60	60	FROM MOTOR NAMEPLATE
p0311	RATED MOTOR SPEED	1765	3490	FROM MOTOR NAMEPLATE
p0314	MOTOR POLE PAIR NUMBER	0	0	AUTOMATICALLY CALCULATED
p0316	MOTOR TORQUE CONSTANT	N/A	N/A	NOT AVAILABLE FOR INDUCTION MOTOR
p0322	MAXIMUM MOTOR SPEED	60	60	ALLOWS MOTOR TO SPIN FULL SPEED
p0323	MAXIMUM MOTOR CURRENT	N/A	N/A	NOT AVAILABLE FOR INDUCTION MOTOR
p0335	MOTOR COOLING TYPE	1	1	FORCED COOLING
p0500	TECHNOLOGY APPLICATION	1	1	PUMPS AND FANS
p0640	CURRENT LIMIT	15.5	7.4	125% OF THE PUMP FLA
p0922	PROFIDRIVE TELEGRAM SELECTION	1	1	STANDARD TELEGRAM 1, PZD-2/2
p0970	RESET DRIVE PARAMETERS	0	0	INACTIVE (SET TO 1 TO RESET PARAMETERS)
p1080	MINIMUM SPEED	30	30	MINIMUM MOTOR SPEED
p1082	MAXIMUM SPEED	60	60	MAXIMUM MOTOR SPEED
p1120	RAMP-FUNCTION GENERATOR RAMP-UP TIME	15	15	TIME LIMIT TO MOVE FROM 0 TO MAXIMUM MOTOR SPEED
p1121	RAMP-FUNCTION GENERATOR RAMP-DOWN TIME	30	30	TIME LIMIT TO MOVE FROM MAXIMUM SPEED TO 0
p1135	OFF3 RAMP-DOWN TIME	5	5	TIME TO MOVE FROM MAXIMUM SPEED TO 0 DURING A OFF3 EVENT
p1300	OPEN-LOOP/CLOSED-LOOP CONTROL	20	20	SPEED CONTROL
p1900	MOTOR DATA IDENTIFICATION	0	0	INHIBITED
p3900	COMPLETION OF QUICK COMMISSIONING	1	1	SAVES THE QUICK COMMISSIONING SETTINGS
P8920[0...239]	SET NAME OF STATION	SINAMICS-G120-CU240E-2PN		SET DURING SOFTWARE INSTALLATION
p8921[0]	IP ADDRESS OF STATION [0]	192	192	FIRST IP ADDRESS NUMBER
p8921[1]	IP ADDRESS OF STATION [1]	168	168	SECOND IP ADDRESS NUMBER
p8921[2]	IP ADDRESS OF STATION [2]	0	0	THIRD IP ADDRESS NUMBER
p8921[3]	IP ADDRESS OF STATION [3]	4	4	FOURTH IP ADDRESS NUMBER
p8923[0]	SUBNET MASK OF STATION [0]	255	255	FIRST SUBNET MASK NUMBER
p8923[1]	SUBNET MASK OF STATION [1]	255	255	SECOND SUBNET MASK NUMBER
p8923[2]	SUBNET MASK OF STATION [2]	255	255	THIRD SUBNET MASK NUMBER
p8923[3]	SUBNET MASK OF STATION [3]	0	0	FOURTH SUBNET MASK NUMBER



THIS DRAWING AND THE INFORMATION CONTAINED HERIN IS THE PROPERTY OF AMIAD WATER SYSTEMS. ANY USE OR REPRODUCTION THEREOF WITHOUT THE WRITTEN PERMISSION OF AMIAD WATER SYSTEMS ENGINEERING DEPARTMENT IS STRICTLY PROHIBITED. TEQUATIC™ IS A TRADEMARK OF THE DOW CHEMICAL COMPANY (DOW) OR AN AFFILIATED COMPANY OF DOW, USED UNDER LICENSE.

DRAWING DATE:		DRAWING TITLE: TEQUATIC™ PLUS C-SERIES SKID PANEL	
SCALE: SHT. 10 OF 10		DRAWING NUMBER:	REV. NO. 4
DRAWN BY:		CATALOG NUMBER: 720102-002456	
REV.	DATE	NOTES	BY
GENERAL REVISIONS		CHKD BY:	APP. BY:
		GENERAL TOLERANCES ALL DIMENSIONS IN INCHES (EXCEPT AS NOTED)	ANGULAR ± 1° FRACTIONAL ± 1/8 DEC: 2PL ± 0.05, 3PL ± 0.010



120-J Talbert Road, Mooresville, NC 28117

800-648-9260 | [www.amiadusa.com](http://www.amiadusa.com)

---

Copyright © 2018 Amiad Water Systems Ltd. All rights reserved.

TEQUATIC™ is a trademark of The Dow Chemical Company ("Dow") or an affiliated company of Dow, used under license

The contents of this document, including without limitation, all information and materials, images, illustrations, data, drawings, names and any other such materials that appear in this document are the sole property of Amiad Water Systems Ltd., including any intellectual property rights, whether registered or not, and all know-how contained or embodied therein. Amiad may alter, remove or change the content without any further notice. You may not reproduce, copy, modify, create derivative works from, sell or participate in any sale of, or exploit in any way, in whole or in part, any of this document or its content.

The confidential nature of and/or privilege in the file enclosed is not waived or lost as a result of a mistake or error in this file. If you received this file in error, please notify Amiad immediately at [infousa@amiad.com](mailto:infousa@amiad.com).

This document does not replace any certified drawing, procedure, or information provided by Amiad in reference to a specific customer, site, or project.

Amiad assumes that all users understand risks involved within this file and/or its attached materials. This document is given in good faith and is not intended to impose any obligation to Amiad. While every effort has been made to ensure the information in this manual is accurate and complete, we would appreciate if you can bring any errors or omissions to the knowledge of Amiad. Consult Amiad experts or its authorized representatives if you have any questions.



**Headquarter:** 54/18 Bui Quang La, Ward 12, Go Vap District, HCMC, Vietnam  
**Branch office:** 77 DHT10B, Dong Hung Thuan Ward, District 12, HCMC, Vietnam  
**Phone:** (028) 6258 5368 – (028) 6291 9568  
**Email:** [info@atswatertechnology.com](mailto:info@atswatertechnology.com)  
**Website:** [www.atswatertechnology.com](http://www.atswatertechnology.com)