

Data sheet

iSave[®] Energy Recovery Device

iSave 50 / iSave 70



Table of Contents

Contents

1.	General information.....	1
2.	Benefits.....	1
3.	Applications.....	1
4.	Technical data.....	2
4.1	iSave without motor.....	2
4.2	iSave with IEC motor.....	4
4.3	iSave with NEMA motor.....	5
5.	Performance curves.....	6
5.1	Flow at different rpm.....	6
5.2	iSave 50 flow curves.....	6
5.3	iSave 70 flow curves.....	6
5.4	Torque curve for iSave 50 and iSave 70.....	7
5.5	Mixing curve.....	7
6.	Temperature and corrosion.....	8
6.1	Operation.....	8
7.	Installation.....	8
7.1	Operation and mounting.....	8
7.2	Horizontal mount.....	8
7.3	Connection to inlet or discharge ports:.....	9
7.4	Filtration.....	9
7.5	Noise.....	9
7.5	RO systems with an iSave.....	10
8.	Dimensions and connections.....	12
8.1	iSave 50-70 without electric motor.....	12
8.2	iSave 50-70 with with IE3 motor 18.5 kW on base frame vertical_front mounted.....	13
8.3	iSave 50-70 with with IE3 motor 18.5 kW on base frame vertical_back mounted.....	14
8.4	iSave 50-70 with with IE3 motor 18.5 kW on base frame horizontal.....	15
8.4	iSave 50-70 with NEMA motor 30 HP on base frame vertical - front mounted.....	16
8.5	iSave 50-70 with NEMA motor 30 HP on base frame vertical - back mounted.....	18
8.5	iSave 50-70 with NEMA motor 30 HP on base frame horizontal.....	19
9.	Service.....	21
9.1	Warranty.....	21
9.2	Operational conditions of concern.....	21
9.3	Maintenance.....	21
9.4	Repair assistance.....	21
10.	Accessories.....	21
11.	Useful documents.....	21

1. General information

Energy Recovery Devices (ERD) are used in reverse osmosis (RO) systems to recycle the energy held in discharged brine from the membranes. Thus, iSave 50 and iSave 70 are designed for use with low viscosity and corrosive fluid such as sea water.

The Danfoss iSave Energy Recovery Devices all consist of an isobaric pressure exchanger and a positive displacement pump combined into one compact unit. The high-pressure booster pump is based on the vane pump principle enabling a very light and compact design. The vane pumps are fixed displacement pumps in which the flow

is proportional to the number of revolutions (rpm) of the driving shaft – enabling flow control. Speed control is made by a VFD. The iSave design ensures lubrication of the moving parts by the fluid itself.

All parts included in the iSave 50 & 70 are designed to provide long service life with a constant high efficiency and minimum service required.

Unlike a centrifugal pump, it produces a similar flow at a given speed no matter what discharge pressure.

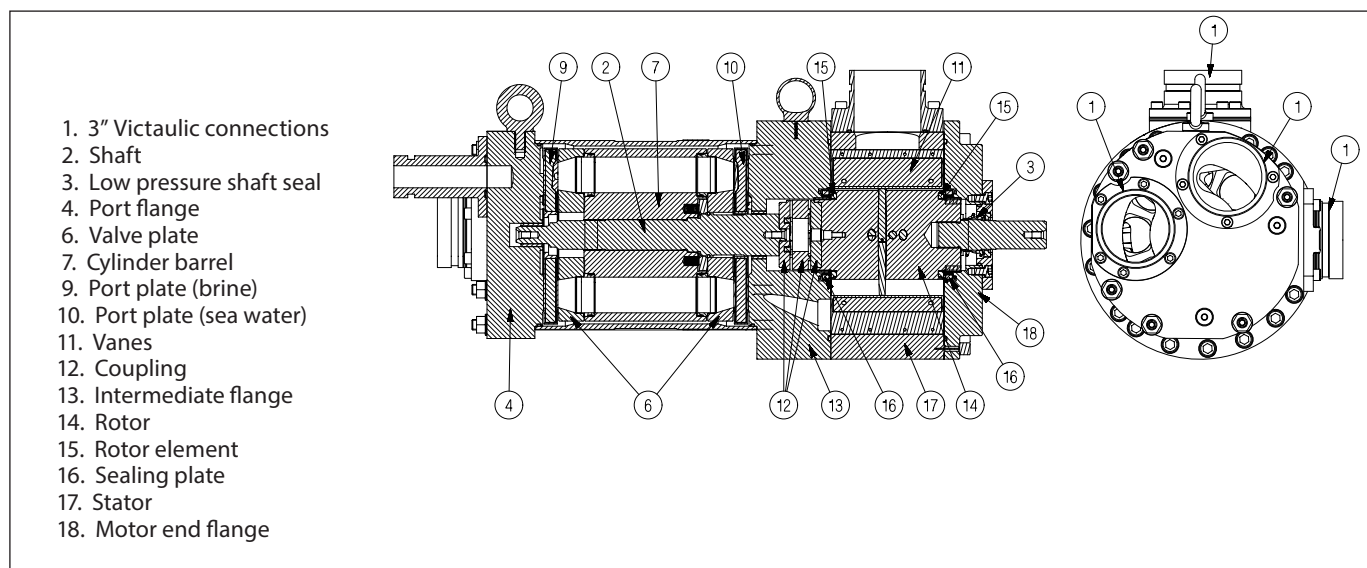

2. Benefits

- Significant power savings and low specific energy consumption (SEC)
- Simple and space-saving installation with both pump and pressure exchanger in one unit
- Simple system design and monitoring without requirement for high-pressure flow meters
- Simple operation with design that prevents overspin/overflushing
- Easy modular service
- Corrosion resistance (all wetted parts are made of high corrosion-resistant materials e.g. Super Duplex or Duplex)
- Fewer components

3. Applications

Danfoss iSave ERDs are built into a broad range of RO desalination plant around the world. Typical applications for iSave 50 - 70 will be:

- Containerized solutions for hotels and resorts on islands as well as coastal regions
- Onboard systems for ships
- Offshore platforms for the oil and gas industry
- Municipal and private waterworks

4. Technical data

4.1 iSave without motor

iSave size		iSave 50	iSave 70
Code number		180F7020	180F7021
Pressure			
Max. differential pressure (HP out - HP in)	barg	5	5
	psig	72	72
Min. pressure HP out (min. allowable working pressure)	barg	40	40
	psig	580	580
Max. pressure HP out (Max. allowable working pressure, MAWP) ¹⁾	barg	83	83
	psig	1200	1200
Min. pressure on HP in, intermittent ^{2) 3)}	barg	2	2
	psig	29	29
Max. pressure LP in (MAWP) ¹⁾	barg	5	5
	psig	72	72
Max. pressure LP in, peak	barg	10	10
	psig	145	145
Min. allowable working pressure LP in	barg	2	2
	psig	29	29
Differential pressure at max. flow (LP in – LP out)	barg	0.53	0.79
	psig	7.69	11.46
Max. static test pressure (HP in and HP out)	barg	108	108
	psig	1566	1566
Max. static test pressure (LP in and LP out)	barg	13	13
	psig	189	189
Speed			
Min. speed	rpm	525	625
Max. speed	rpm	650	875
Typical flow ⁴⁾			
Flow at min. speed, HP out	m ³ /h	42	50
	gpm	184	220
Flow at max. speed, HP out	m ³ /h	52	70
	gpm	228	308
Max. lubrication flow at 60 barg (871 psig)	l/min	25	25
	gpm	6.6	6.6
Peak flow, LP in ¹⁰⁾	m ³ /h	120	120
	gpm	528	528
Max. allowable working flow, LP in ⁷⁾	m ³ /h	57.2	70
	gpm	252	308

Technical specifications			
Media temperature ⁵⁾	°C	2-35	2-35
	°F	36-95	36-95
Ambient temperature	°C	0-50	0-50
	°F	32-122	32-122
Filtration requirements (nominal) ⁶⁾	µm	5 micron melt-blown	
Salinity increase at membrane at 40% recovery rate at balanced flow ⁹⁾		2-3%	
Weight (dry)	kg	164	164
	lb	362	362
Weight (operation with water)	kg	172	172
	lb	379	379
Noise			
Sound pressure level L _{PA} 1 m ⁸⁾	dB(A)	83	86
Torque data			
Max. allowable working torque	Nm	170	190
	lbf-ft	125	140
Max. starting torque (stick/slip)	Nm	180	180
	lbf-ft	132	132

- ¹⁾ Max. allowable working pressure of continuous operation. For lower and higher pressure, please contact Danfoss.
- ²⁾ Typical pressure level at start-up and permeate flush.
- ³⁾ Intermittent pressure is acceptable for less than 10 minutes within a period of 6 hours.
- ⁴⁾ Typical average flow at 60 barg and 3 barg differential pressure
- ⁵⁾ Dependent on NaCl concentration.
- ⁶⁾ Please see section 7.4 filtration.
- ⁷⁾ Continuous operation: iSave can operate continuously with up to 10% over flush with the limitation that the flow rate at LP inlet shall not exceed 70 m³/h.
- ⁸⁾ A-weighted sound pressure level at 1 m from the pump unit surfaces (reference box) acc. to EN ISO 20361 section 6.2. The noise measurements are performed acc. to EN ISO 3744:2010 on a motor-pump-unit at max. pressure and rpm.
- ⁹⁾ Balanced flow: The mixing rate is defined at balanced flow when HP-out is equal to LP-in.
- ¹⁰⁾ At system start-up: iSave can run for up to 10 min. With 150% of max. rated flow at LP inlet. The time where max. rated flow is exceeded should be kept as short as possible to minimize wear.

4.2 iSave with IEC motor

iSave size		iSave 50	iSave 70
Code number (vertical)		180F7038	180F7040
Code number (horizontal)		180F7023	180F7025
Pressure, Speed, Flow, Temperature and Torwue are identical with		180F7020 and	180F7021
Efficiency			
Efficiency at max. speed at 60 barg (871 psig)	%	93.7	92.4
Technical specifications			
Media temperature ⁵⁾	°C	2-35	2-35
	°F	36-95	36-95
Filtration requirements (nominal) ⁶⁾		5 micron melt-blown	
Weight (dry) vertical/horizontal	kg	441/463	441/463
	lb	972/1021	972/1021
Weight (operation with water) vertical/horizontal	kg	470/471	470/471
	lb	1036/1038	1036/1038
Noise			
Sound pressure level L_{pA} 1 m ²⁾	dB(A)	83	86
Footprint			
Footprint (vertical position) ³⁾	m ²	0.44	0.44
	foot ²	4.71	4.71
Footprint (horizontal position) ³⁾	m ²	0.76	0.76
	foot ²	8.14	8.14
Torque data			
Max. allowable working torque	Nm	170	177
	lbf-ft	125	130.5
Max. starting torque (stick/slip)	Nm	180	180
	lbf-ft	132	132
Motor data			
Nominal speed	rpm	985	985
Rated current at 400V	A	37	37
Motor size	kW	18.5	18.5
	HP	30.0	30.0
Frame size	IEC	200 L	200 L
	Poles	6	6
Rated motor torque at nominal speed	Nm	177	177
	lbf-ft	130.5	130.5
Rated motor ambient temperature ⁴⁾	°C	40	40
	°F	104	104
Motor insulation	Class	B	B
Motor degrees of protection	IP	55	55

- 2) A-weighted sound pressure level at 1 m from the ERD unit surfaces (reference box) acc. to EN ISO 20361 section 6.2. The noise measurement are performed acc. to EN ISO 3744:2010 on an ERD with motor (motor pump unit) from min. to max. pressure and speed.
- 3) Area covered with recommended IE3 motor configurations (excl. of space to service the ERD)
- 4) For higher temperature, contact Danfoss.
- 5) Dependent on NaCl concentration.
- 6) Please see section 7.4 Filtration
- 7) Typical efficiency for pressure exchanger, booster pump, electrical motor and VFD at 3 barg differential pressure after a system has been commissioned and run in.

4.3 iSave with NEMA motor

iSave size		iSave 50	iSave 70
Code number (vertical)		180U0062	180U0064
Code number (horizontal)		180U0003	180U0005
Pressure, Speed, Flow, Temperature and Torque are identical with		180F7020	180F7021
Efficiency			
Efficiency at max. speed at 60 barg (871 psig) ⁷⁾	%	93.7	92.4
Technical specifications			
Media temperature ⁵⁾	°C	2-35	2-35
	°F	36-95	36-95
Filtration requirements (nominal) ⁶⁾		5 micron melt-blown	
Weight (dry) vertical/horizontal	kg	484/506	484/506
	lb	1067/1116	1067/1116
Weight (operation with water) vertical/horizontal	kg	513/535	513/535
	lb	1131/1179	1131/1179
Noise			
Sound pressure level L _{PA} 1 m ²⁾	dB(A)	83	86
Footprint			
Footprint (vertical position) ³⁾	m ²	0.44	0.44
	foot ²	4.71	4.71
Footprint (horizontal position) ³⁾	m ²	0.76	0.76
	foot ²	8.14	8.14
Torque data			
Max. allowable working torque	Nm	170	177
	lbf-ft	125	130.5
Max. starting torque (stick/slip)	Nm	180	180
	lbf-ft	132	132
Motor data			
Nominal speed	rpm	1180	1180
Rated current at 400V	A	36.2	36.2
Motor size	kW	22.5	22.5
	HP	30.0	30.0
Frame size	NEMA	324/6T	324/6T
	Poles	6	6
Rated motor torque at nominal speed	Nm	179	179
	lbf-ft	132	132
Rated motor ambient temperature ⁴⁾	°C	40	40
	°F	104	104
Motor insulation	Class	B	B
Motor degrees of protection	IP	55	55

²⁾ A-weighted sound pressure level at 1 m from the ERD unit surfaces (reference box) acc. to EN ISO 20361 section 6.2. The noise measurement are performed acc. to EN ISO 3744:2010 on an ERD with motor (motor pump unit) from min. to max. pressure and speed.

³⁾ Area covered with recommended IE3 motor configurations (excl. of space to service the ERD)

⁴⁾ For higher temperature, contact Danfoss.

⁵⁾ Dependent on NaCl concentration.

⁶⁾ Please see section 7.4 Filtration

⁷⁾ Typical efficiency for pressure exchanger, booster pump, electrical motor and VFD at 3 barg differential pressure after a system has been commissioned and run in.

5. Performance curves

5.1 Flow at different rpm

The diagram shows that the HP flow can be changed by changing the rotation speed of the iSave. The flow/rpm ratio is constant, the required flow is obtainable by changing the rotation speed to a required value.

For accurate data and advise, please contact Danfoss High Pressure Pumps.

The iSave is delivered with a 3.1 performance certificate according to EN10204.

5.2 iSave 50 flow curves

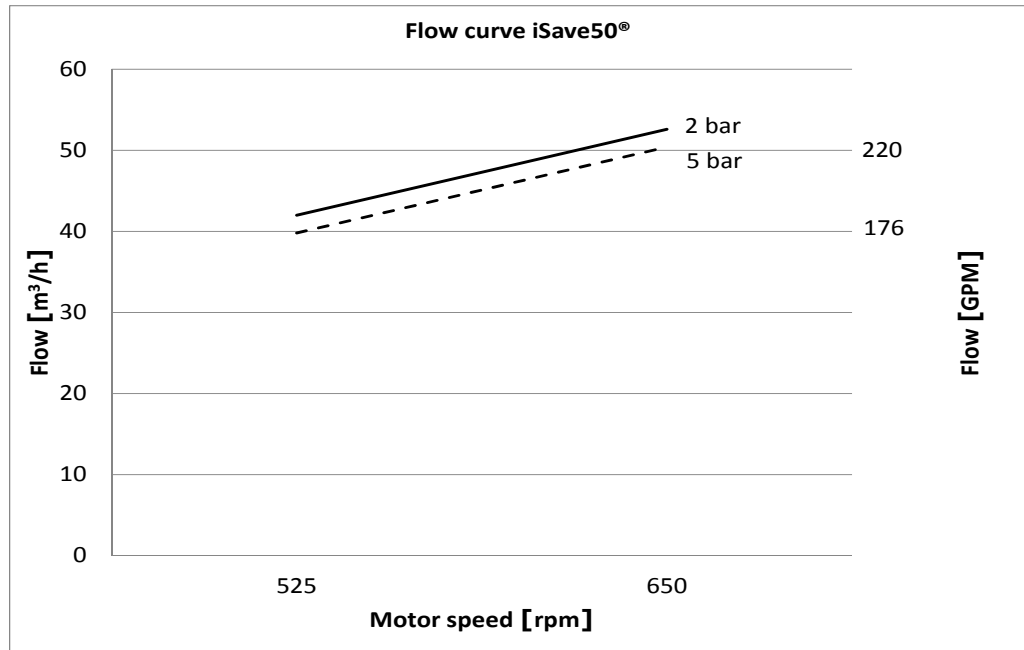

5.3 iSave 70 flow curves

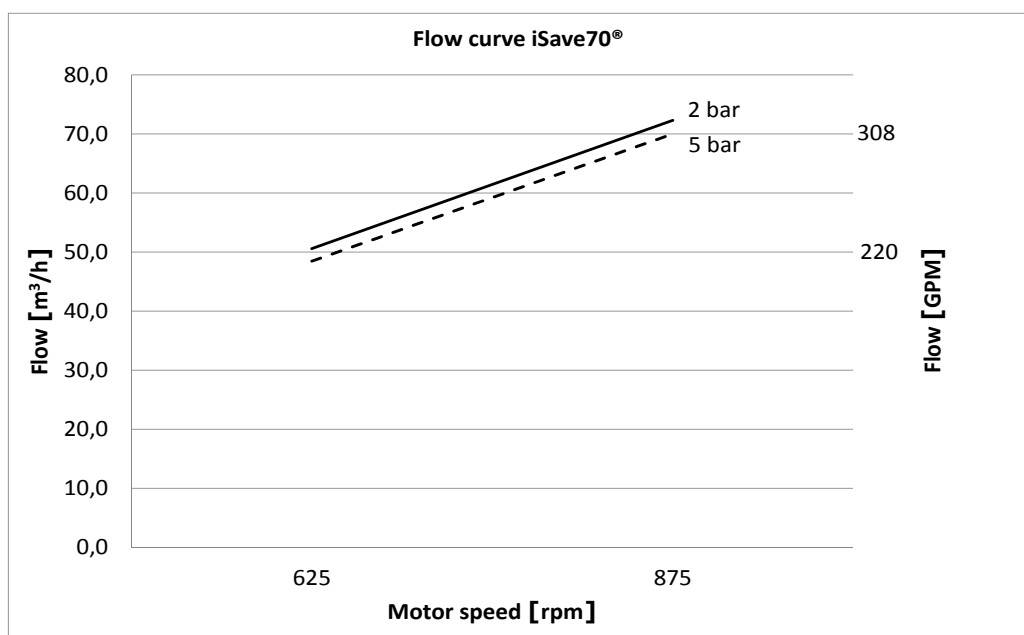

5.4 Torque curve for iSave 50 and iSave 70

Below curve illustrates typical values.

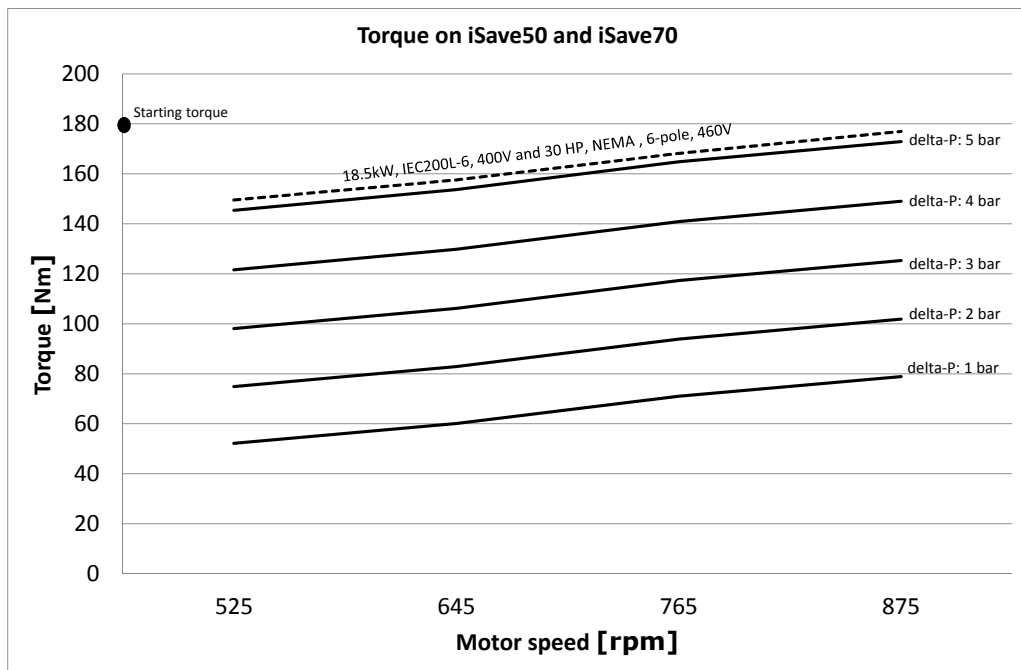

5.5 Mixing curve

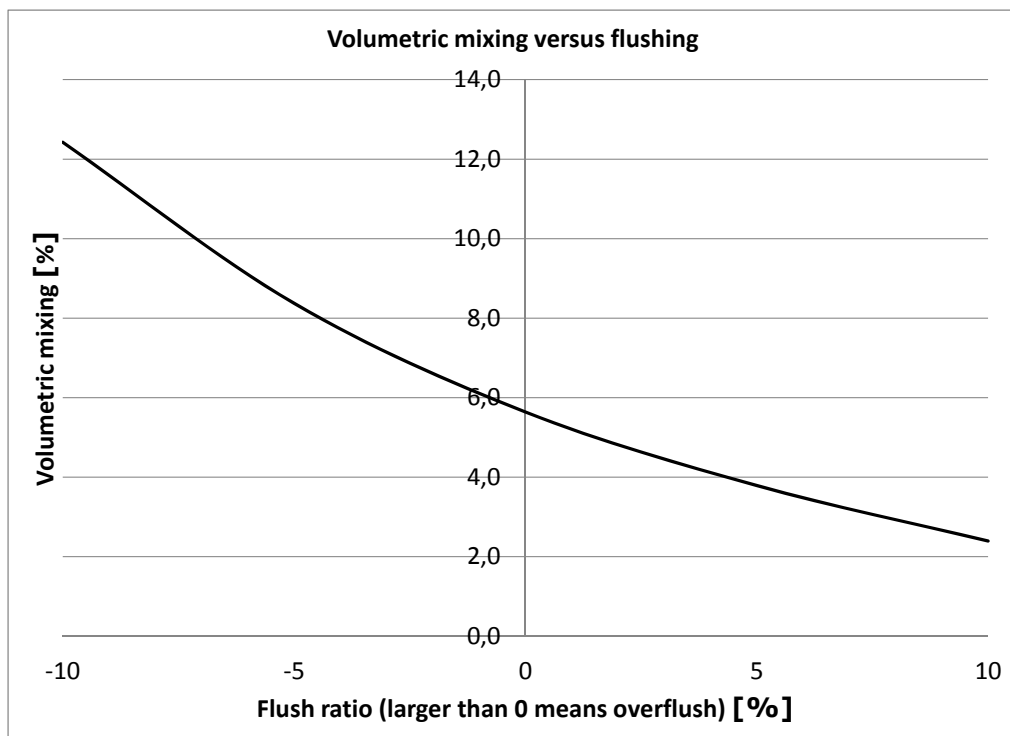

6. Temperature and corrosion

6.1 Operation

The chart below illustrates the corrosive resistance of different types of stainless steel related to NaCl concentration and temperature. All critical parts of the iSave is made of Super Duplex 1.4410/UNS 32 750 or Duplex 1.4462/UNS 32803.

Always flush the iSave with fresh water at operation stop in order to minimize the risk of crevice corrosion.

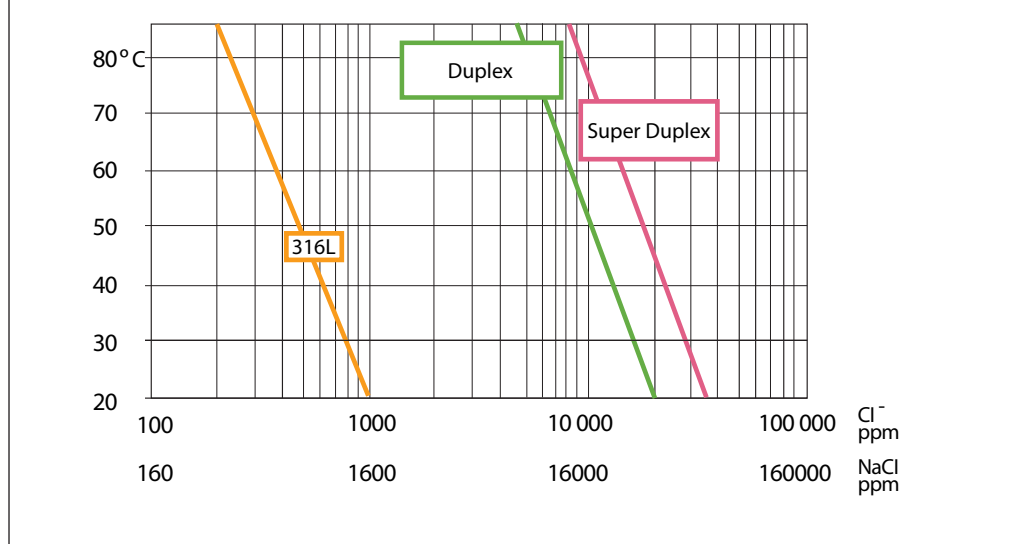

7. Installation

7.1 Operation and mounting

The iSave 50 and iSave 70 can be mounted horizontally and vertically. When mounted vertically, the electric motor must be placed at the top of the iSave

7.2 Horizontal mount

The iSave is delivered with a standard port orientation. The port orientation can be changed by the customer by rotating the combined iSave and bell housing around the center of the motor shaft.

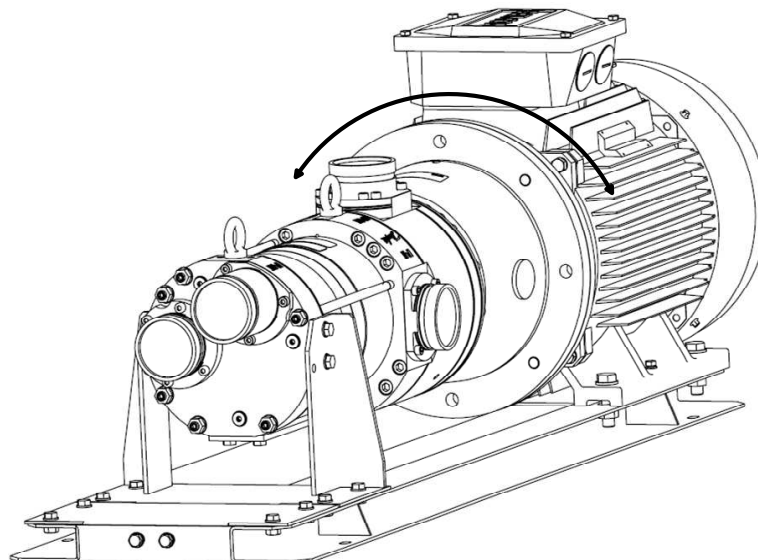

See example below on how to mount the pump and connect it to an electrical motor.

Note: Any axial and radial load on the shaft must be avoided.

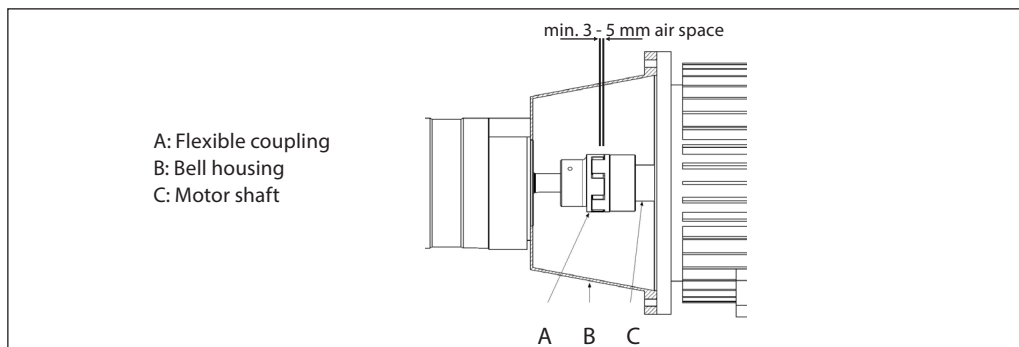

7.3 Connection to inlet or discharge ports:

- When using hard piping, it is important to follow the Guideline 180R9367 - Pipe connection.
- When using flexible hoses, it is recommended to use Hose Whip Restraint. Also follow the guideline 180R9084 - Right and Wrong Hose assembly.

7.4 Filtration

High quality water extends the service life of the whole system. Water to the iSave must be filtered to 3 µm nominal, using melt-blown depth filter with good end sealings. Consult Danfoss for correct choice of filter.

It is important with selection of a proper filter and filter housing to ensure good cartridge end sealing. If there is a high risk of water by-pass it is recommended to use a second stage filter solution.

As the various filters on the market differ greatly, Danfoss High Pressure Pumps recommends using cartridges with consistent, reliable performance and high efficiency and where fibres are blown continuously onto a central support core. High Pressure Pumps does not recommend cartridges requiring any type of binders or resins.

Filters can be purchased from Danfoss High Pressure Pumps. For more information on the importance of proper filtration, please consult our publication "Filtration" (code number 521B1009), which also will provide you with an explanation of filtration definitions and a guidance on how to select the right filter.

7.5 Noise

Since the iSave is mounted on a bell housing and electric motor, the noise level should be determined for a complete system. To minimize vibrations and noise throughout the system, it is important that a horizontal iSave unit is mounted correctly on a frame with dampeners.

Rigid designs with metal pipes cause vibration and noise. It is therefore recommended to use high-pressure flexible hoses between the hard piping in the RO-plant and the iSave or to use multiple connections with Victaulic clamps where possible.

The noise level is influenced by:

- **Speed:** High rpm makes more fluid/structure-borne pulsations/vibrations than low rpm due to higher frequency.

Pressure:

- High pressure makes more noise than low pressure.

Mounting:

- Rigid mounting makes more noise than flexible mounting due to structure-borne vibrations.

Connections to iSave:

- Pipes connected directly to the iSave make more noise than flexible hoses due to structure-borne vibrations.
- Variable frequency drives (VFD): Motors regulated by VFDs can increase noise level if the VFD does not have the right settings.

7.5 RO systems with an iSave

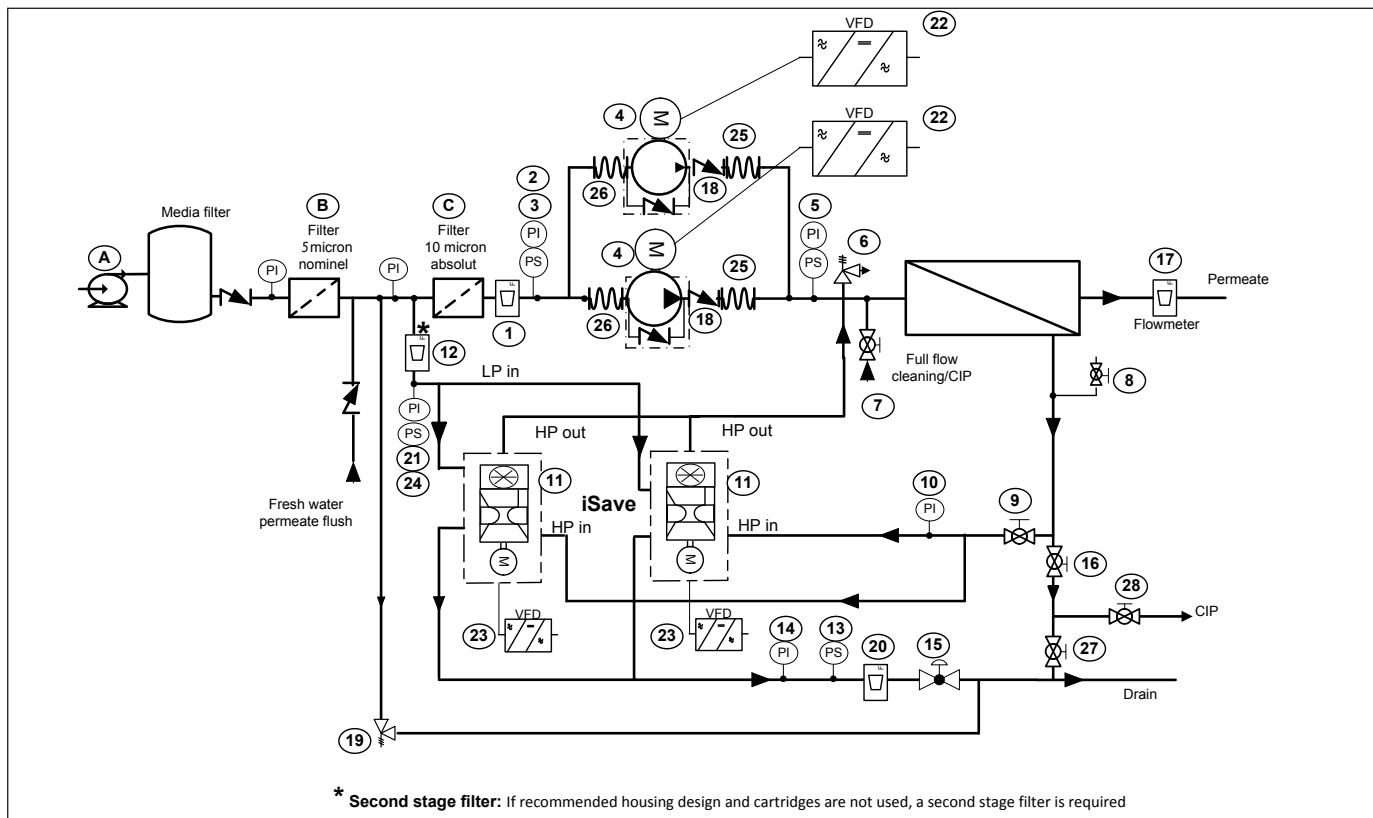

Explanation of P&ID setup

A. **Inlet filter:**

Place inlet filters on LP string in front of the iSave (11). Please see Guide line 521B1009 on Filtration.

If recommended housing design and cartridges are not used, a second stage filter is required, see above (*). Thoroughly clean pipes and flush system prior to start-up.

B. **Inlet pressure:**

Must assure that iSave is running according to specifications. Refer to iSave data sheet. Required: Must assure min. pressure to avoid cavitation. Recommended: Must assure max. pressure to avoid hydraulic and mechanical overload. (13) used for iSave 21 and iSave 40. (24) used for iSave 50 and iSave 70.

C. **Piping and hoses:**

Dimension the piping to obtain minimum pressure loss (large flow, minimum pipe length, minimum number of bends/connections and fittings to prevent pressure loss and flow turbulence). Use flexible hoses to minimize vibrations and noise. Please consult the Danfoss Hoses and Hose Fittings data sheet (521B0909) and Right and wrong Hose assembly (180R9084) for guidance.

D. **Inlet flow control and mixing:**

To balance LP flow up against HP flow on the iSave and control mixing, place a flowmeter on low-pressure inlet (12) or low pressure outlet (20) of the iSave.

E. **Outlet pressure control:**

In order to control the inlet pressure needed a back pressure valve (15) must be installed in the common outlet pipe from the iSaves. The valve should be designed to control flow. It is recommended to use a manual valve with lock function or an automatic controlled valve.

F. **Variable speed and overload protection:**

Install a VFD to control the speed of the iSave and protect it against mechanical overload. See instruction 180R9372 for guidance of VFD settings.

G. **LP discharge flow control:**

See "E".

H. **Air venting:**

Install an air bleed valve (8) on the highest point of the high-pressure piping to ensure the air is purged from the system before startup.

I. Pressure relief (high pressure):

The pressure relief valve (6) protects the whole system against pressure overload and relieves the water if the pressure exceeds the maximum set pressure. If the high-pressure pump is a positive displacement pump, the pump can build up a very high pressure that will exceed mechanical strength of the membrane housing, pipes and other accessories. When using Danfoss APP pumps with Danfoss VCM check valves, it is recommended to place a pressure relief valve or pressure safety valve as illustrated. In case the Danfoss check valves are not used, the valve must be placed between pump and check valve (See 180R9371, Design Guide Pressure safety valve in seawater RO system for more details).

J. Pressure relief (low pressure):

The pressure relief valve or pressure safety valve (19) protects the low-pressure pipes against pressure overload and relieves the water if the pressure exceeds the maximum allowable pressure.

For a more elaborate description of the P&ID setup, please consult the Danfoss Design Guide Piping & Instrumentation Diagram (P&ID) (180R9370) or contact Danfoss.

The iSave 50 and iSave 70 can be mounted in parallel. For more information, please see "Design Guide Parallel-coupled APP and iSave" -180R9354 or contact Danfoss.

8. Dimensions and connections

8.1 iSave 50-70 without electric motor

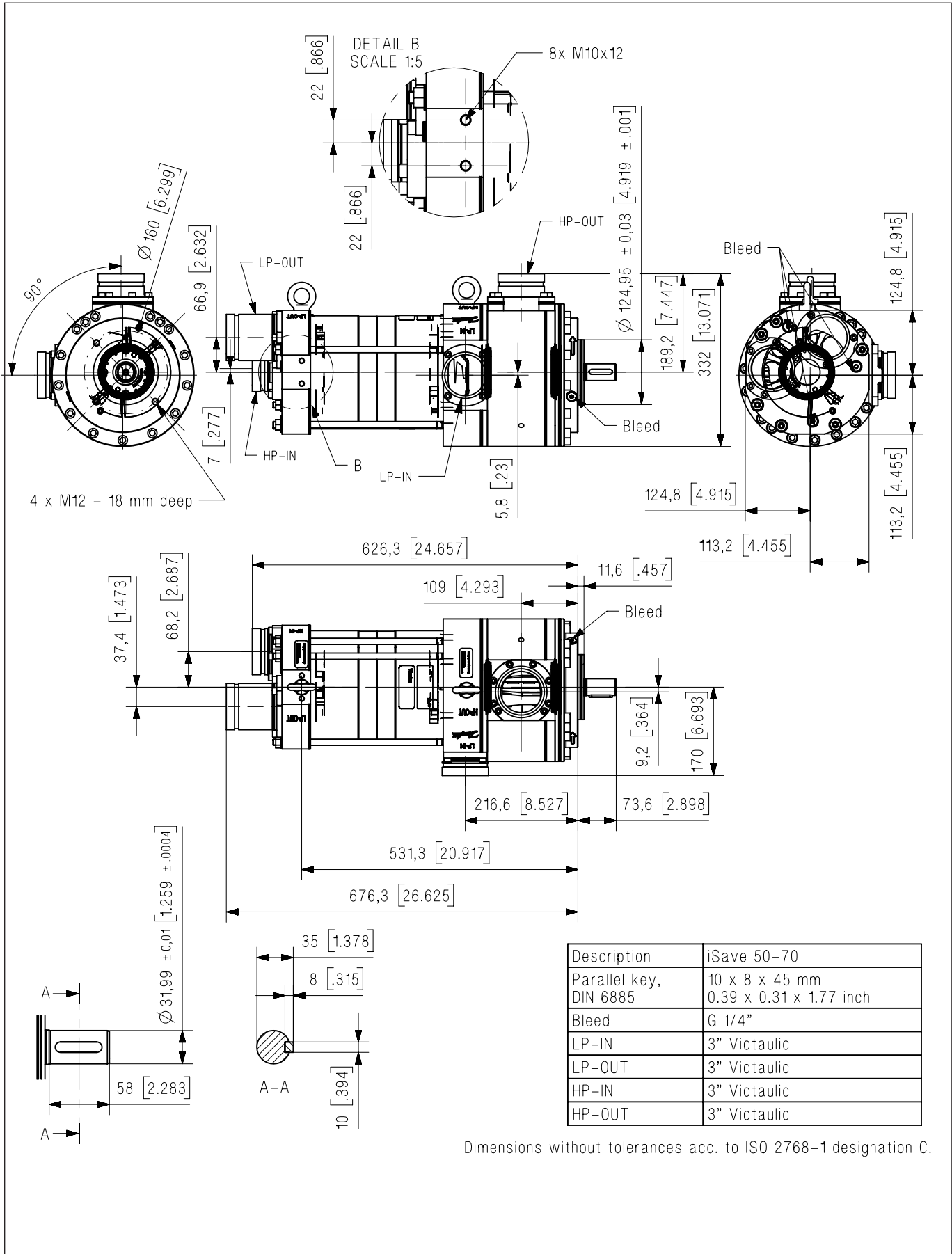

8.2 iSave 50-70 with with IE3 motor 18.5 kW on base frame vertical_front mounted

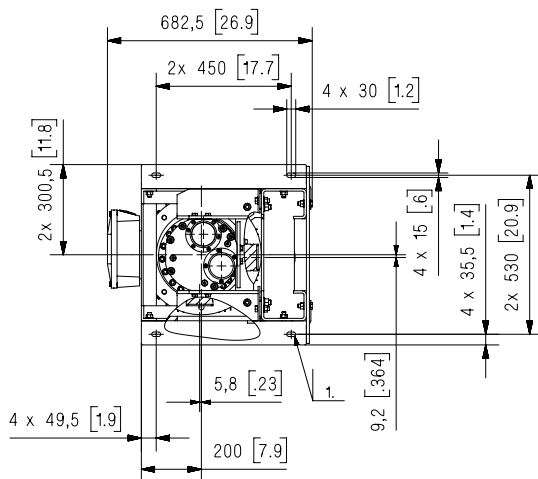

1. M12 anchoring/bolts.
Bolt quality min. class 8.8.
Torqued acc. to recommendation
from bolt supplier.
Foundation/anchoring acc. to
Eurocode 2: 1992-1-1.

A

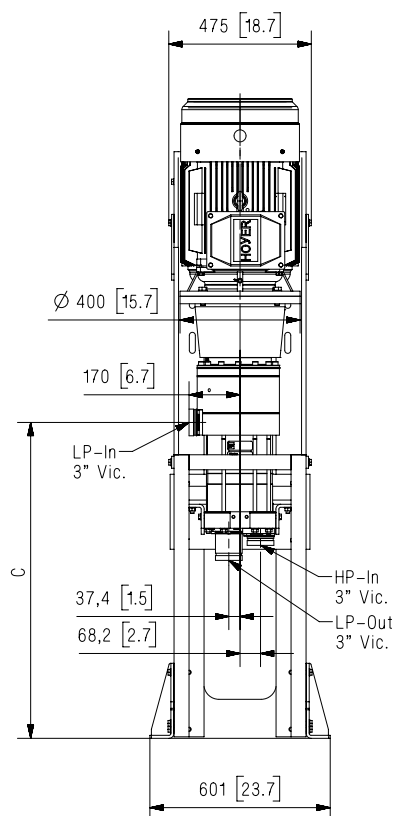
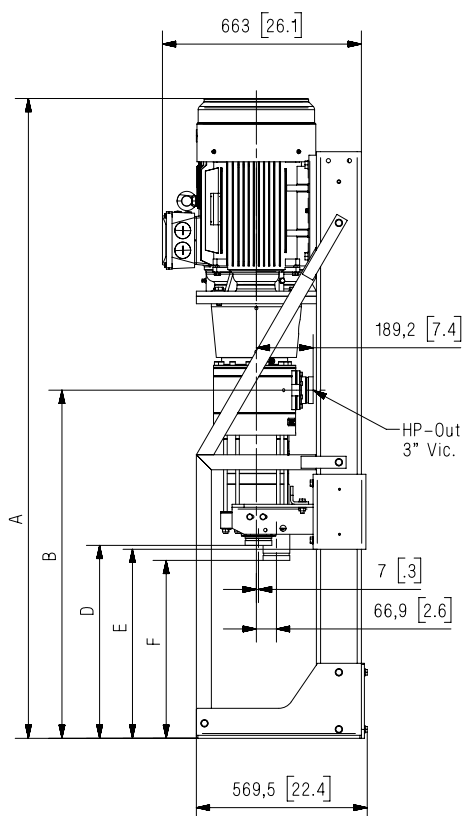

Dimensions without tolerances acc. to ISO 2768-1 designation C.
Positions 1, 2 and 3 refers to the three different heights where
the iSave can be mounted on the baseframe.

Dimension	Position 1	Position 2	Position 3 *
A	2132,3 [83.9]	1979,8 [77.9]	1827,3 [71.9]
B	1160,2 [45.7]	1007,7 [39.7]	855,2 [33.7]
C	1052,7 [41.4]	900,2 [35.4]	747,7 [29.4]
D	643 [25.3]	490,5 [19.3]	338 [13.3]
E	630 [24.8]	477,5 [18.8]	325 [12.8]
F	593 [23.3]	440,5 [17.3]	288 [11.3]

* Unit is delivered in position 3!

8.3 iSave 50-70 with with IE3 motor 18.5 kW on base frame vertical_back mounted

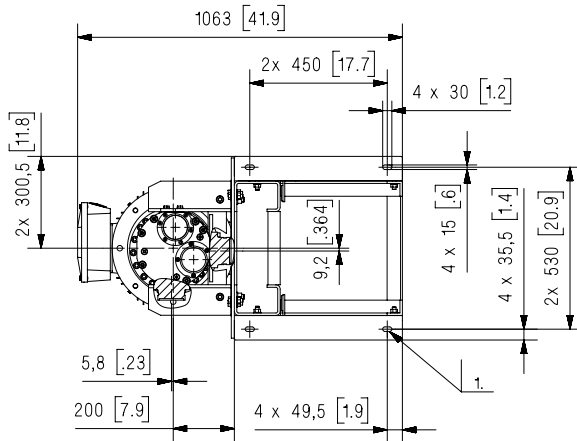

1. M12 anchoring/bolts.
Bolt quality min. class 8.8.
Torqued acc. to recommendation
from bolt supplier.
Foundation/anchoring acc. to
Eurocode 2: 1992-1-1.

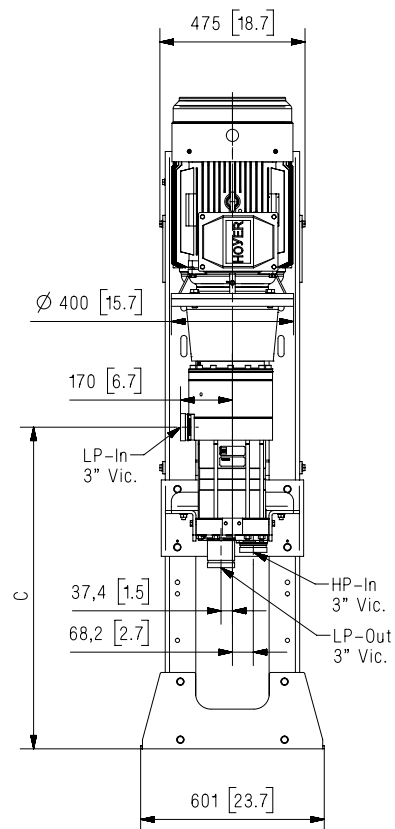
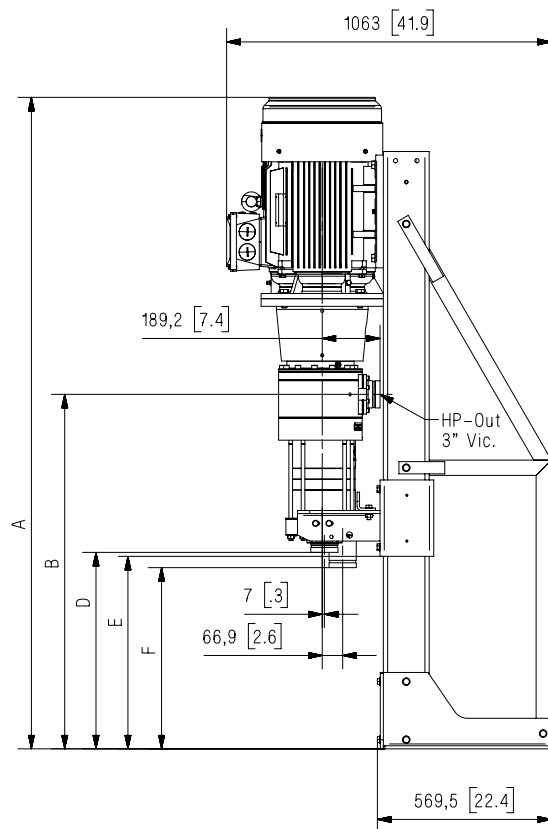

Dimensions without tolerances acc. to ISO 2768-1 designation C.
Positions 1, 2 and 3 refers to the three different heights where
the iSave can be mounted on the baseframe.

Dimension	Position 1	Position 2	Position 3
A	2132,3 [83.9]	1979,8 [77.9]	1827,3 [71.9]
B	1160,2 [45.7]	1007,7 [39.7]	855,2 [33.7]
C	1052,7 [41.4]	900,2 [35.4]	747,7 [29.4]
D	643 [25.3]	490,5 [19.3]	338 [13.3]
E	630 [24.8]	477,5 [18.8]	325 [12.8]
F	593 [23.3]	440,5 [17.3]	288 [11.3]

* Unit is delivered in position 3!

8.4 iSave 50-70 with with IE3 motor 18.5 kW on base frame horizontal

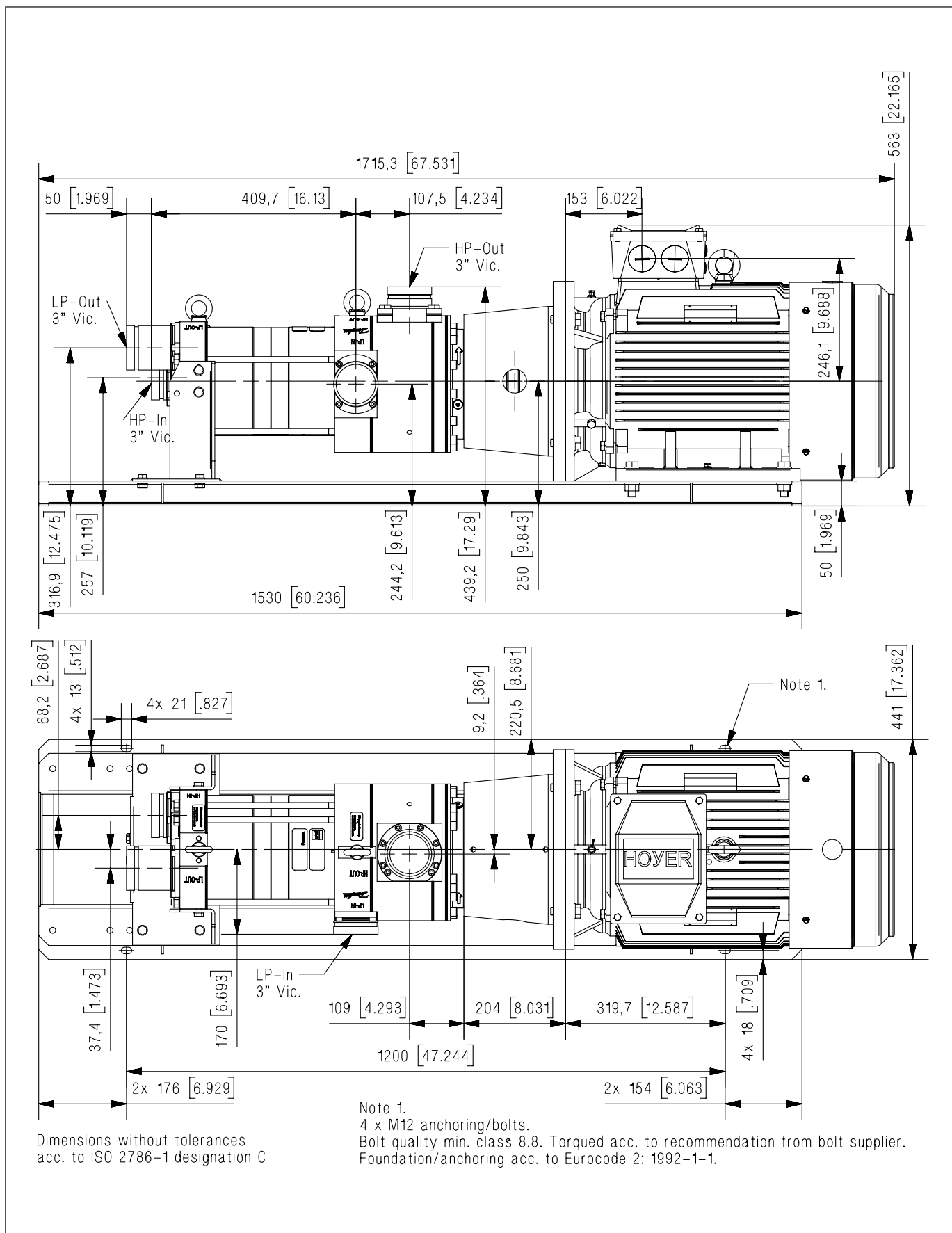

8.4 iSave 50-70 with NEMA motor 30 HP on base frame vertical - front mounted

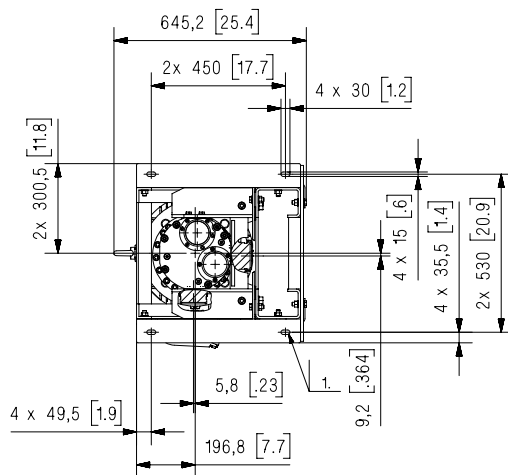

1. M12 anchoring/bolts.
Bolt quality min. class 8.8.
Torqued acc. to recommendation
from bolt supplier.
Foundation/anchoring acc. to
Eurocode 2: 1992-1-1.

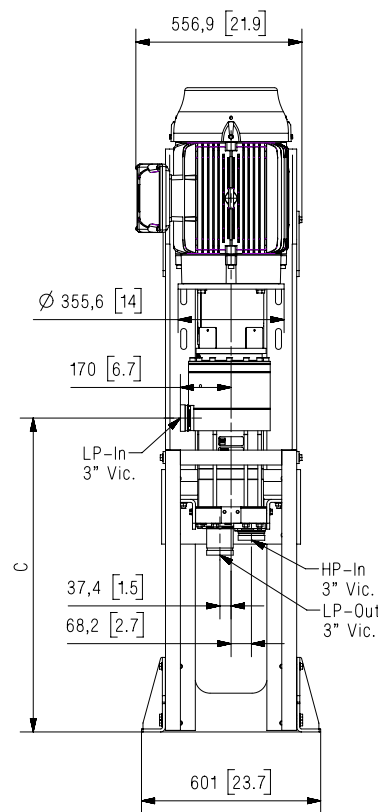
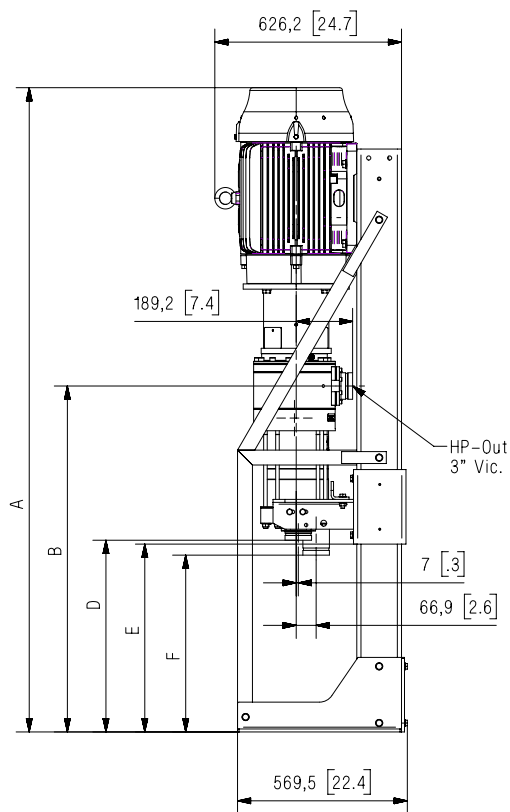

Dimensions without tolerances acc. to ISO 2768-1 designation C.
Positions 1, 2 and 3 refers to the three different heights where
the iSave can be mounted on the baseframe.

Dimension	Position 1	Position 2	Position 3
A	2160,8 [85,1]	2008,3 [79,1]	1855,8 [73.1]
B	1160,2 [45.7]	1007,7 [39.7]	855,2 [33.7]
C	1052,7 [41.4]	900,2 [35.4]	747,7 [29.4]
D	643 [25.3]	490,5 [19.3]	338 [13.3]
E	630 [24.8]	477,5 [18.8]	325 [12.8]
F	593 [23.3]	440,5 [17.3]	288 [11.3]

* Unit is delivered in position 3!

8.5 iSave 50-70 with NEMA motor 30 HP on base frame vertical - back mounted

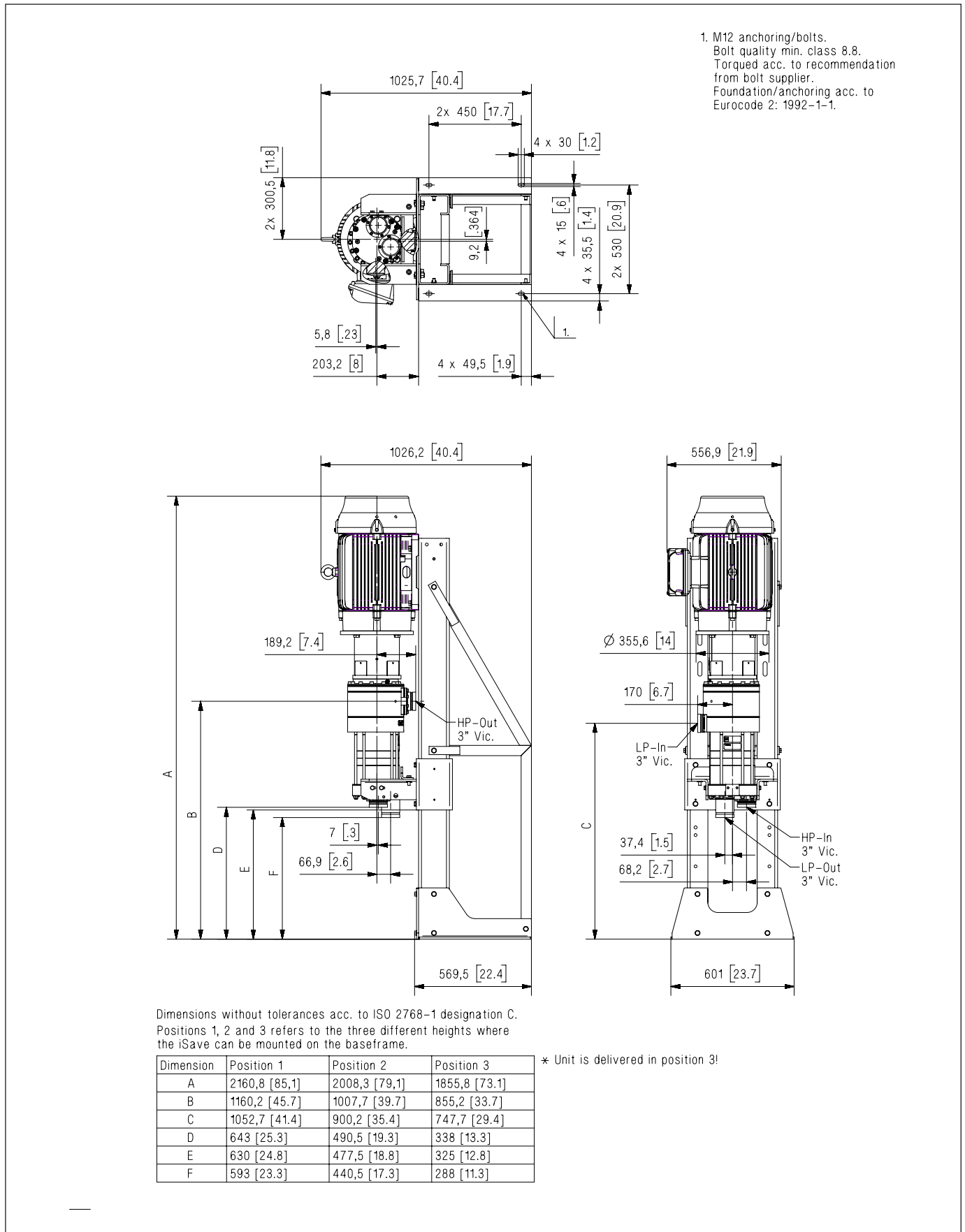

8.5 iSave 50-70 with NEMA motor 30 HP on base frame horizontal

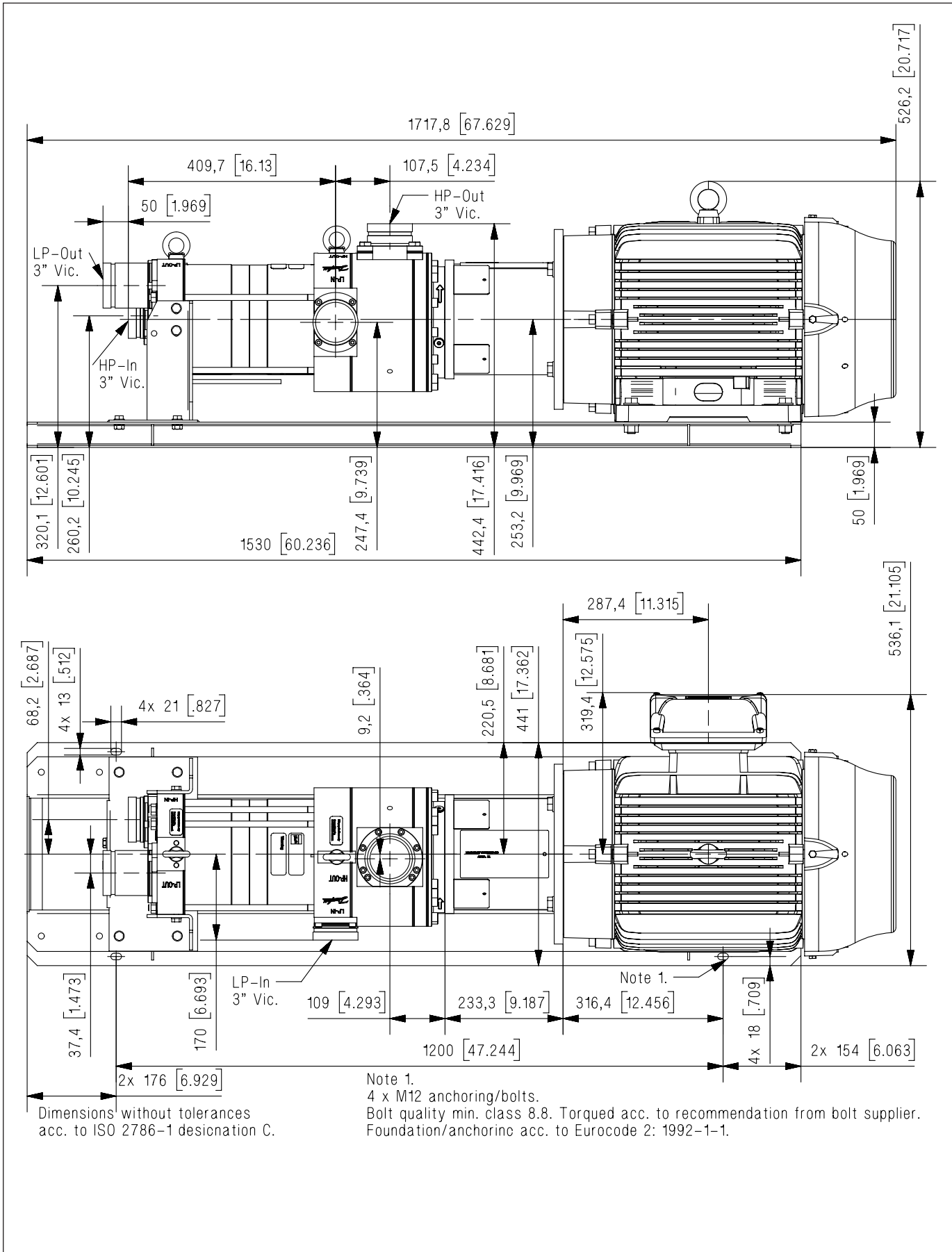

9. Service

9.1 Warranty

The Danfoss iSave is designed for long operation, low maintenance and reduced lifecycle costs.

Provided that the iSave has been running according to the Danfoss specifications, Danfoss guarantees one year service-free operation, however, max. 18 months from date of production.

**9.2 Operational conditions of concern
Particular attention should be paid to the following factors to avoid increased wear and spare parts costs:**

- Insufficient filtration
- Insufficient bleeding and venting
- Running at speeds outside specifications
- Wrong direction of rotation
- Insufficient flushing or periods of standstill with sea water inside the iSave.

9.3 Maintenance

Periodic inspections are required to ensure worn parts (if any), are replaced in due time. Operational conditions such as water quality should be taken into consideration when determining the frequency of the inspections. Danfoss recommends yearly inspections.

It is recommended to order the purpose-designed tool kit.

9.4 Repair assistance

In case of irregular function of the Danfoss RO components, please contact Danfoss High Pressure Pumps.

10. Accessories

Description	Type	Code no.
3" Inlet hose kit - 2 m (79") 6 barg (87 psig)	3" Victaulic, style 77	180Z0144
3" Outlet hose - 1 m (39.4") 80 barg (1160 psig)	3" Victaulic, style 77	180Z0611
3" Outlet hose - 1.79 m (70.0") 80 barg (1160 psig)	3" Victaulic, style 77	180Z0612
Coupling iSave 50 - iSave 70	Softex 55H7-32H7	180Z4003
Base plate horizontal	IEC200/NEMA324TC	180Z4007
Base plate vertical	IEC200/NEMA324TC	180Z4025

11. Useful documents

Literature number	Description
180R9213	Start and stop of the SWRO with iSave
180R9214	Membrane cleaning of the RO system with the iSave
180R9354	Parallel coupled APP and iSave
180R9367	Pipe connections
180R9371	Pressure safety valve in the SWRO system
180R9372	APP and iSave overload protection
180R9370	Review sheet P&ID
521B1009	Filtration
-	iSave selection tool (hpp.danfoss.com)



ATS WATER
TECHNOLOGY

Headquarter: 54/18 Bui Quang La, Ward 12, Go Vap District, HCMC, Vietnam

Office: 77 DHT10B, Dong Hung Thuan Ward, District 12, HCMC, Vietnam

Phone: (028) 6258 5368 – (028) 6291 9568

Email: info@atswatertechnology.com

Website: www.atswatertechnology.com

Danfoss A/S

High Pressure Pumps • danfoss.com • +45 7488 2222 • highpressurepumps@danfoss.com

Any information, including, but not limited to information on selection of product, its application or use, product design, weight, dimensions, capacity or any other technical data in product manuals, catalogues descriptions, advertisements, etc. and whether made available in writing, orally, electronically, online or via download, shall be considered informative, and is only binding if and to the extent, explicit reference is made in a quotation or order confirmation. Danfoss cannot accept any responsibility for possible errors in catalogues, brochures, videos and other material. Danfoss reserves the right to alter its products without notice. This also applies to products ordered but not delivered provided that such alterations can be made without changes to form, fit or function of the product.

All trademarks in this material are property of Danfoss A/S or Danfoss group companies. Danfoss and the Danfoss logo are trademarks of Danfoss A/S. All rights reserved.