

ITEM	DESCRIPTION	MATERIAL	QTY
1	GROOVED END PIPE (AWWA C606 STANDARD)	METALLIC/NON METALLIC	2
2	COUPLING HOUSING	CE8MN/CE3MN (DUPLEX/SUPERDUPLEX STAINLESS STEEL)	2
3	GASKET	EPDM RUBBER	1
4	ROUND HEAD, SQUARE NECK BOLT	316 STAINLESS STEEL	2
5	WASHER	316 STAINLESS STEEL	2
6	HEAVY HEX NUT	SILICON BRONZE/316 STAINLESS STEEL	2

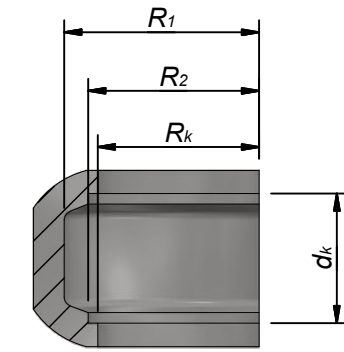
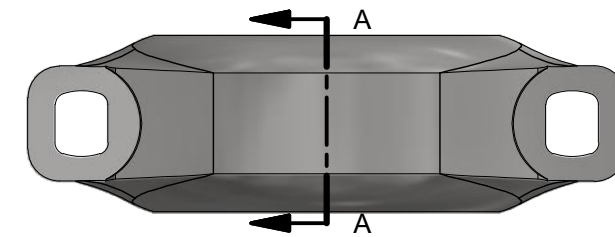
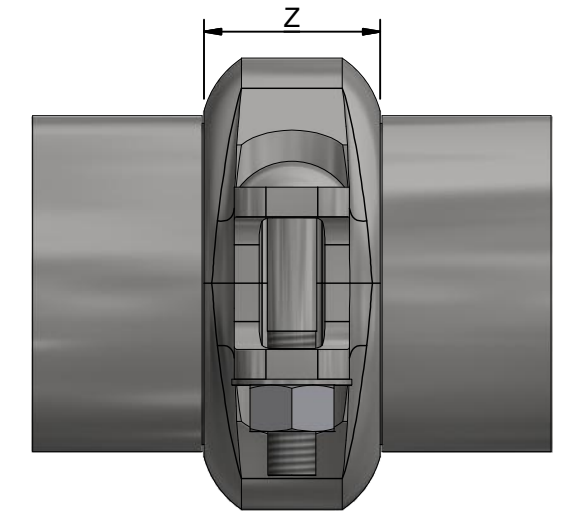
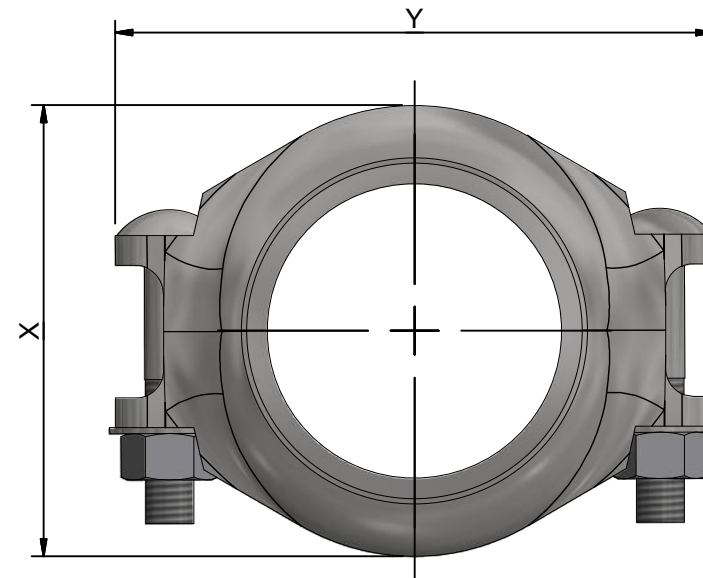

SECTION A-A

PRESSURE RATING:

NOMINAL SIZES	RATED PRESSURE	PROOF TEST PRESSURE
0.75" - 4"	1500 PSI (103 BAR)	2250 PSI (155 BAR)

DIMENSIONS:

NOMINAL SIZE INCH	X INCH [MM]	Y INCH [MM]	Z INCH [MM]	dk INCH [MM]	R1 INCH [MM]	R2 INCH [MM]	Rk INCH [MM]	APPROX. WT LB [KG]
3/4	2.00 [50.8]	3.20 [81.3]	1.71 [43.4]	1.37 [34.8]	0.81 [20.5]	0.54 [13.6]	0.48 [12.1]	1.10 [0.50]
1	2.40 [61.0]	3.50 [88.8]	1.71 [43.4]	1.37 [34.8]	1.00 [25.4]	0.67 [16.9]	0.60 [15.2]	1.16 [0.53]
1-1/4	2.72 [69.1]	3.74 [95.0]	1.71 [43.4]	1.35 [34.3]	1.11 [28.2]	0.85 [21.6]	0.77 [19.6]	1.53 [0.70]
1-1/2	3.04 [80.0]	4.17 [105.9]	1.71 [43.4]	1.35 [34.3]	1.23 [31.2]	0.98 [24.9]	0.90 [22.7]	1.57 [0.71]
2	3.50 [88.9]	4.81 [122.2]	1.79 [45.5]	1.35 [34.3]	1.47 [37.3]	1.21 [30.7]	1.13 [28.7]	2.44 [1.11]
2-1/2	3.92 [99.6]	5.38 [136.5]	1.85 [47.0]	1.35 [34.3]	1.72 [43.7]	1.46 [37.0]	1.37 [34.7]	2.79 [1.27]
3	4.70 [119.4]	6.23 [158.2]	1.85 [47.0]	1.35 [34.3]	2.03 [51.6]	1.78 [45.2]	1.68 [42.7]	3.59 [1.63]
4	5.90 [149.7]	7.40 [180.0]	2.02 [51.3]	1.50 [38.1]	2.64 [67.1]	2.28 [57.9]	2.17 [55.2]	6.08 [2.76]

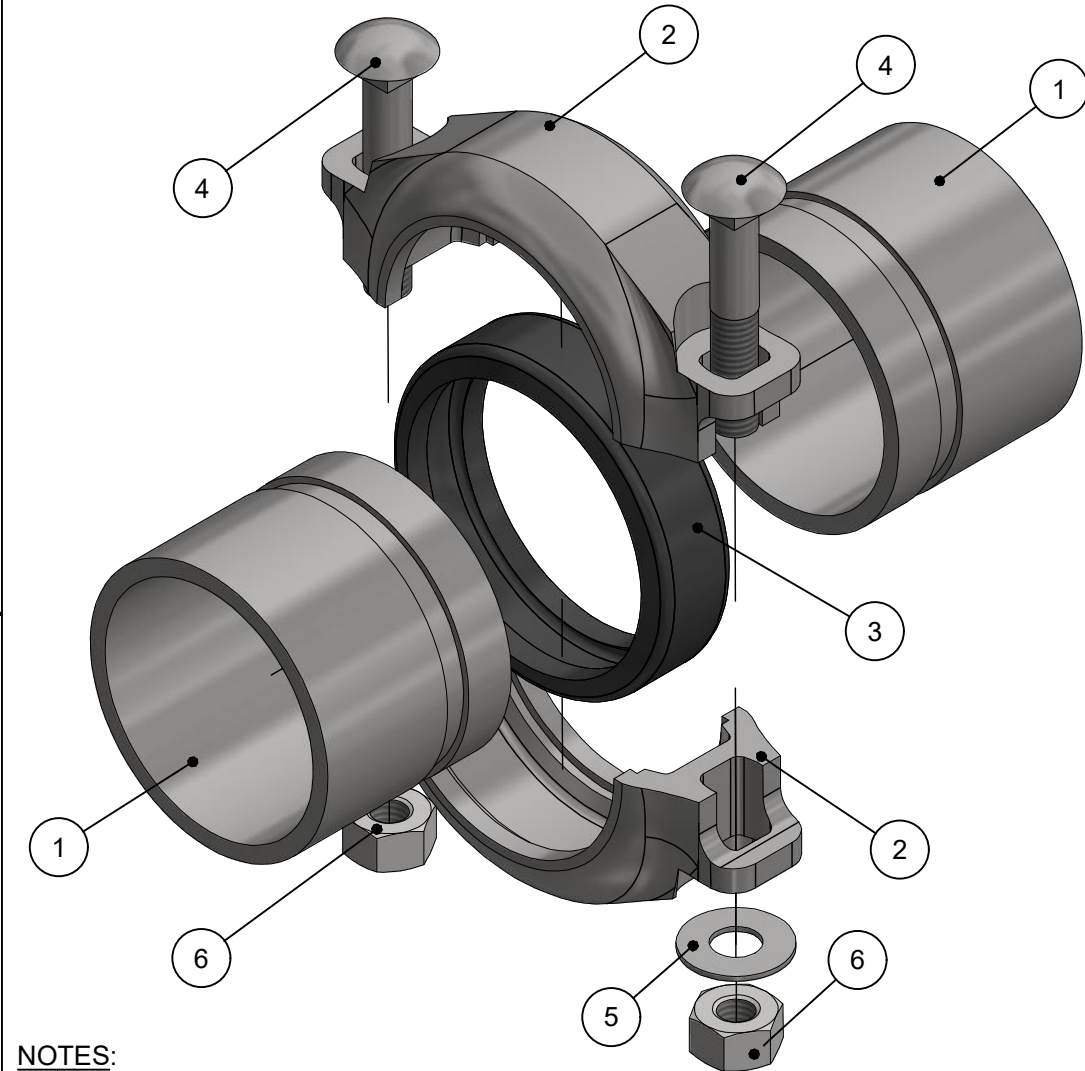

NOTES:

- DIMENSIONS SHOWN IN THE DRAWING ARE INDICATIVE. FOR DETAILED INFORMATION ON GD&T, CONTACT PIEDMONT
- COUPLING IS RATED FOR SCH. 40 PIPE (OR THICKER) WITH CUT GROOVES ONLY
- HOUSING MATERIAL IS DUPLEX (CE8MN) OR SUPER DUPLEX (CE8MN/CE3MN) STAINLESS STEEL, CONFORM TO ASTM A995/A995M-13
- BOLTS ARE ROUND HEAD, SQUARE NECK, 316SS BOLTS, CONFORM TO ASME B18.5-2012
- NUTS ARE HEAVY HEX SILICON BRONZE/316SS, CONFORM TO ASME/ANSI 18.2.2-1987
- WASHERS ARE 316SS, CONFORM TO ASME 18.21.1-2009
- GASKETS ARE EPDM RUBBER (FLUSH-FIT/C-SHAPE)

PROPRIETARY AND CONFIDENTIAL NOTE:  
THE INFORMATION CONTAINED IN THIS DRAWING IS THE SOLE PROPERTY OF PIEDMONT PACIFIC. ANY REPRODUCTION IN PART OR AS A WHOLE WITHOUT THE WRITTEN PERMISSION OF PIEDMONT PACIFIC IS PROHIBITED.

REV	DATE	DESCRIPTION	DRAWN	CHKD	ENG	APPVD
1.0	04-05-2018	INITIAL VERSION	JF	CZZ		

UNLESS NOTED OTHERWISE  
INTERPRETATION:  
ANSI Y14.5  
TOLERANCES: ±0.02" (0.75 MM)  
ANGLES: 45°  
HOLE SIZES: ±0.005" (0.125 MM)  
HOLE CENTERS: ±0.005" (0.125 MM)  
SURFACE FINISH ON PART: N/A  
SURFACE FINISH ON DRAWING: 32  
DO NOT SCALE PRINTS

PIEDMONT PACIFIC  
GROOVE END FLEXIBLE PIPE COUPLING

TITLE:				
STYLE S COUPLING ASSEMBLY				
SCALE:	UNIT:	DRAWING NO.	SHEET:	REVISION:
N/A	INCH [MM]	1.0	1.0	1.0

