

ITEM	DESCRIPTION	MATERIAL	QTY
1	GROOVED END PIPE (AWWA C606 STANDARD)	METALLIC/NON METALLIC	2
2	COUPLING HOUSING	CE8MN (DUPLEX/SUPER DUPLEX) OR CE3MN (SUPER DUPLEX)	2
3	GASKET	EPDM RUBBER	1
4	ROUND HEAD, SQUARE NECK BOLT	316 STAINLESS STEEL	2
5	HEAVY HEX NUT	316 STAINLESS STEEL	2

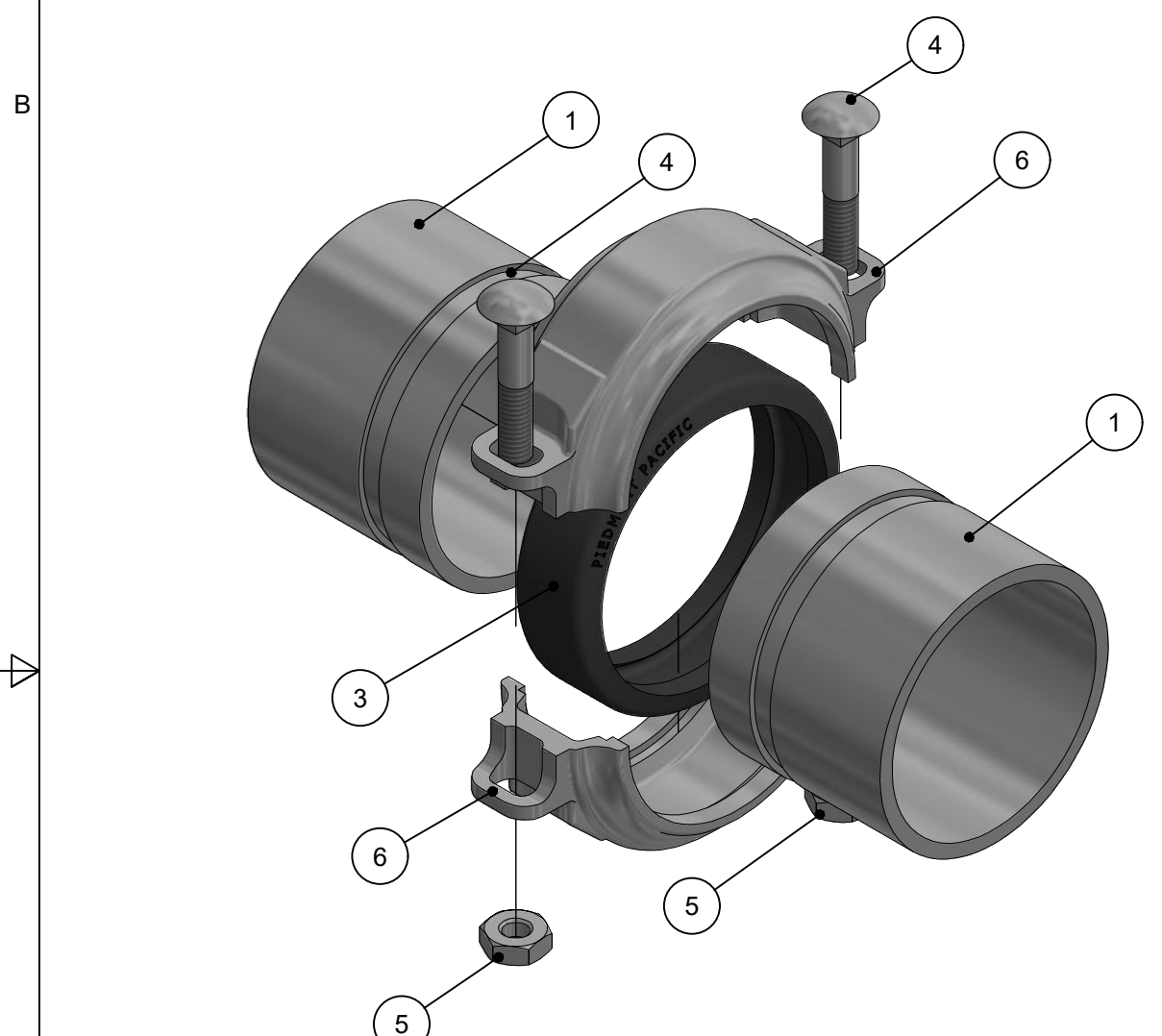

**PRESSURE RATING**

NOMINAL SIZES	RATED PRESSURE	PROOF TEST PRESSURE
0.75" - 4"	600 PSI (41 BAR)	900 PSI (62 BAR)
6" - 16"	400 PSI (28 BAR)	600 PSI (41 BAR)

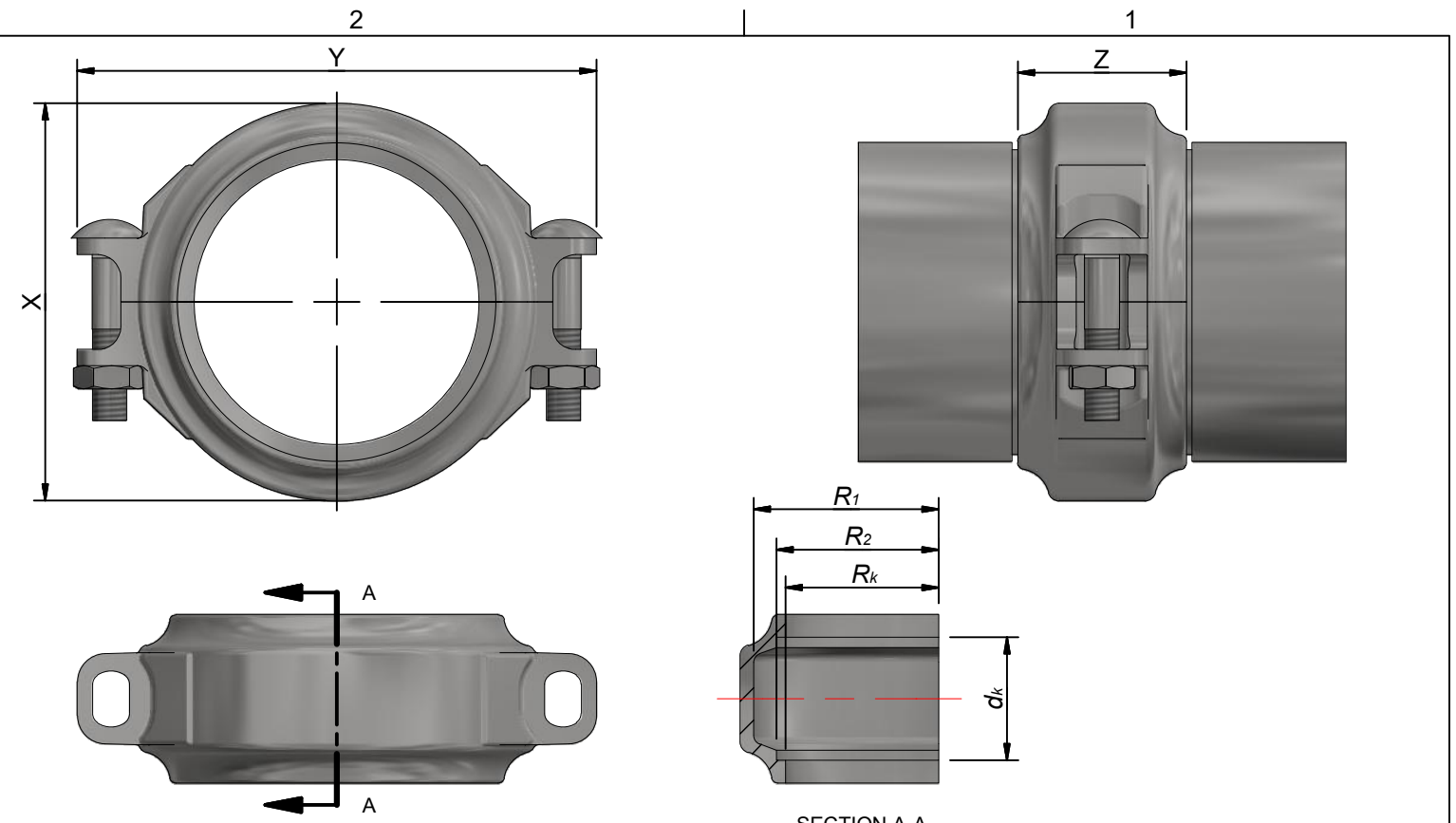

**DIMENSIONS**

NOMINAL SIZE	X	Y	Z	dk	R1	R2	Rk	APPROX. WT
INCH	INCH [MM]	INCH [MM]	INCH [MM]	INCH [MM]	INCH [MM]	INCH [MM]	INCH [MM]	LB [KG]
3/4	1.82 [46.2]	2.90 [73.7]	1.68 [42.7]	1.35 [34.3]	0.81 [20.6]	0.54 [13.6]	0.48 [12.1]	0.63 [0.28]
1	2.18 [55.6]	3.50 [89.0]	1.70 [43.2]	1.37 [34.7]	1.00 [25.3]	0.66 [16.9]	0.60 [15.2]	0.72 [0.33]
1-1/4	2.42 [61.5]	3.60 [91.4]	1.70 [43.2]	1.35 [34.3]	1.11 [28.2]	0.85 [21.6]	0.77 [19.6]	0.77 [0.35]
1-1/2	2.66 [67.6]	3.79 [96.3]	1.70 [43.2]	1.35 [34.3]	1.23 [31.2]	0.98 [25.0]	0.90 [22.7]	0.79 [0.36]
2	3.14 [79.8]	4.13 [104.8]	1.70 [43.2]	1.35 [34.3]	1.47 [37.3]	1.21 [30.7]	1.13 [28.7]	0.85 [0.39]
2-1/2	3.69 [93.7]	5.00 [127.0]	1.70 [43.2]	1.35 [34.3]	1.72 [43.7]	1.46 [37.0]	1.37 [34.7]	1.40 [0.64]
3	4.36 [110.7]	5.70 [144.8]	1.85 [47.0]	1.35 [34.3]	2.03 [51.6]	1.78 [45.2]	1.68 [42.7]	1.83 [0.83]
4	5.70 [144.8]	7.50 [190.5]	2.02 [51.3]	1.50 [38.1]	2.67 [67.8]	2.28 [57.9]	2.17 [55.2]	3.25 [1.47]
6	7.80 [198.0]	9.75 [247.7]	1.90 [48.3]	1.50 [38.1]	3.71 [94.2]	3.34 [84.8]	3.23 [82.1]	5.11 [2.32]
8	9.94 [252.4]	12.13 [308.0]	2.25 [57.2]	1.75 [44.5]	4.78 [121.4]	4.35 [110.4]	4.23 [107.3]	8.71 [3.95]
10	12.12 [307.8]	14.26 [362.1]	2.25 [57.2]	1.75 [44.5]	5.85 [148.5]	5.41 [137.5]	5.29 [134.3]	11.07 [5.02]
12	14.18 [360.2]	16.26 [412.9]	2.25 [57.2]	1.75 [44.5]	6.85 [174.0]	6.41 [162.9]	6.27 [159.3]	12.64 [5.73]
14	16.44 [417.7]	20.30 [515.7]	2.99 [75.8]	2.13 [54.0]	7.47 [189.8]	7.04 [178.7]	6.89 [175.2]	45.89 [20.81]
16	18.94 [481.0]	18.94 [481.0]	2.93 [74.4]	2.17 [55.1]	8.46 [214.9]	8.03 [204.0]	7.89 [200.4]	67.76 [30.73]

**NOTES:**

- DIMENSIONS SHOWN IN THE DRAWING ARE INDICATIVE. FOR DETAILED INFORMATION ON GD&T, CONTACT PIEDMONT
- COUPLING IS RATED FOR SCH. 40 PIPE WITH CUT GROOVES ONLY
- HOUSING MATERIAL IS CE8MN (DUPLEX/SUPER DUPLEX) OR CE3MN (SUPER DUPLEX), CONFORM TO ASTM A995/A995M - 13a
- BOLTS ARE ROUND HEAD, SQUARE NECK, 316SS, CONFORM TO ASME B18.5-2012
- NUTS ARE HEAVY HEX 316SS, CONFORM TO ASME/ANSI 18.2.2-1987
- GASKETS ARE EPDM RUBBER (FLUSH-FIT/C-SHAPE)

**PROPRIETARY AND CONFIDENTIAL NOTE**  
 THE INFORMATION CONTAINED IN THIS DRAWING IS THE SOLE PROPERTY OF PIEDMONT PACIFIC. ANY REPRODUCTION IN PART OR AS A WHOLE WITHOUT THE WRITTEN PERMISSION OF PIEDMONT PACIFIC IS PROHIBITED.

REV	DATE	REVISION DESCRIPTION	DRAWN	CHKD	ENG	APPVD
1	11-09-2015	GENERAL COUPLING ASSEMBLY OF STYLE F	AH	CZZ	AH	
2	25-11-2015	F14 DESCRIPTION HAS BEEN ADDED	AH	CZZ	AH	
3	19-04-2016	WEIGHT INFORMATION ADDED AND FORMAT REVISED	AH	CZZ	AH	
4	10-01-2018	WEIGHT INFORMATION ADDED AND FORMAT REVISED	JF	CZZ		
6	16-03-2018	REVISED LAYOUT	JF	CZZ		

UNLESS NOTED OTHERWISE  
 INTERPRETATION: ANSI Y14.5  
 TOLERANCES: ±0.02" (±0.75 MM)  
 ANGLES: ±1°  
 HOLE SIZES: ±0.001" (±0.25 MM)  
 HOLE CENTERS: ±0.001" (±0.25 MM)  
 SURFACE FINISH ON PART: 125  
 SURFACE FINISH ON DRAWING: 32  
 DO NOT SCALE PRINTS

**PIEDMONT PACIFIC**  
**GROOVE END FLEXIBLE PIPE COUPLING**

TITLE: STYLE F COUPLING ASSEMBLY				
SCALE:	UNIT:	DRAWING NO.:	SHEET:	REVISION:
N/A	INCH [MM]	1.0	1.0	6