

ITEM	DESCRIPTION	MATERIAL	QTY
1	GROOVED END PIPE (AWWA C606 STANDARD)	METALLIC/NON METALLIC	2
2	COUPLING HOUSING	CF8M (316 STAINLESS STEEL)	2
3	GASKET	EPDM RUBBER	1
4	ROUND HEAD, SQUARE NECK BOLT	316 STAINLESS STEEL	2
5	HEAVY HEX NUT	316 STAINLESS STEEL	2

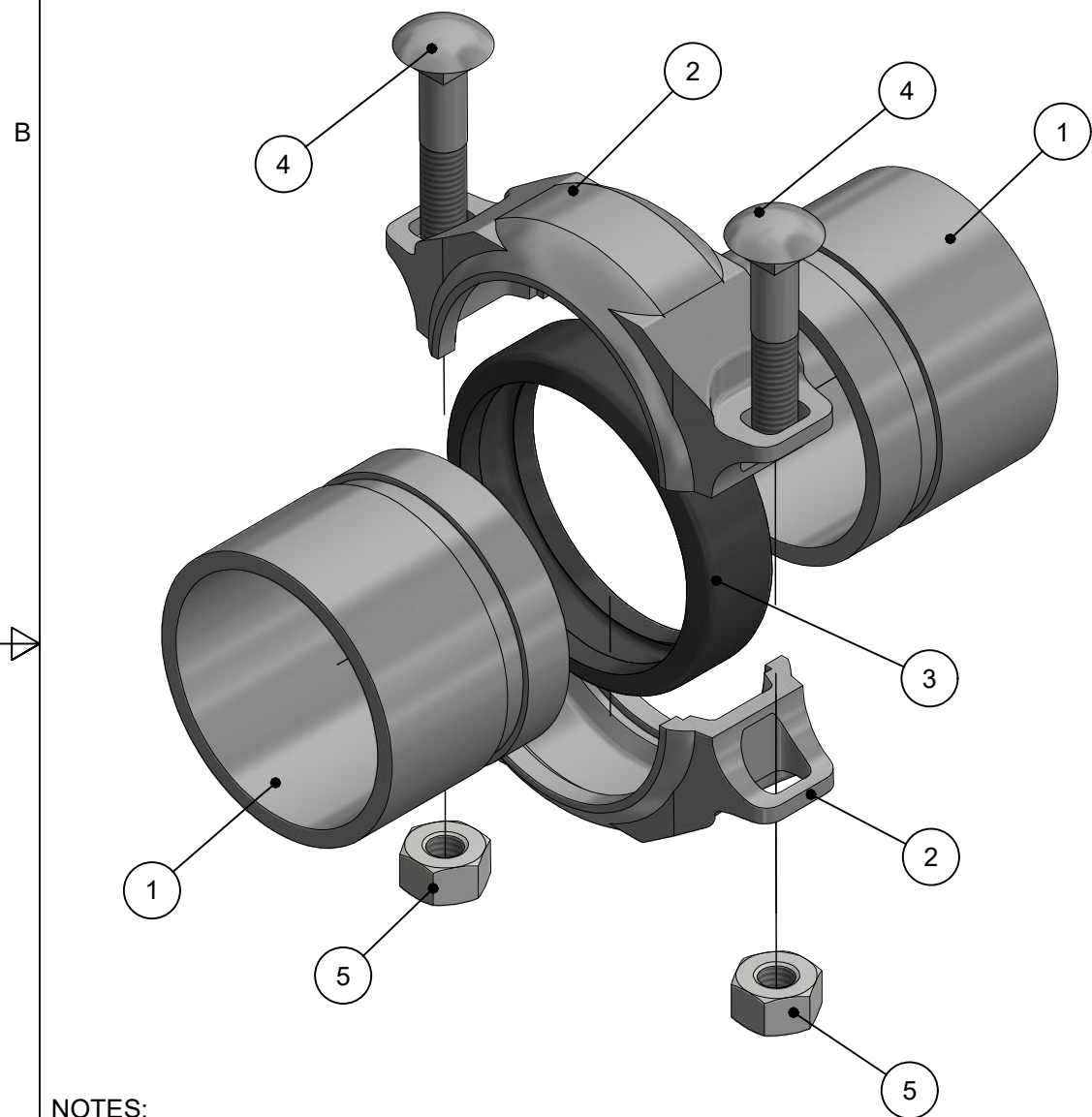
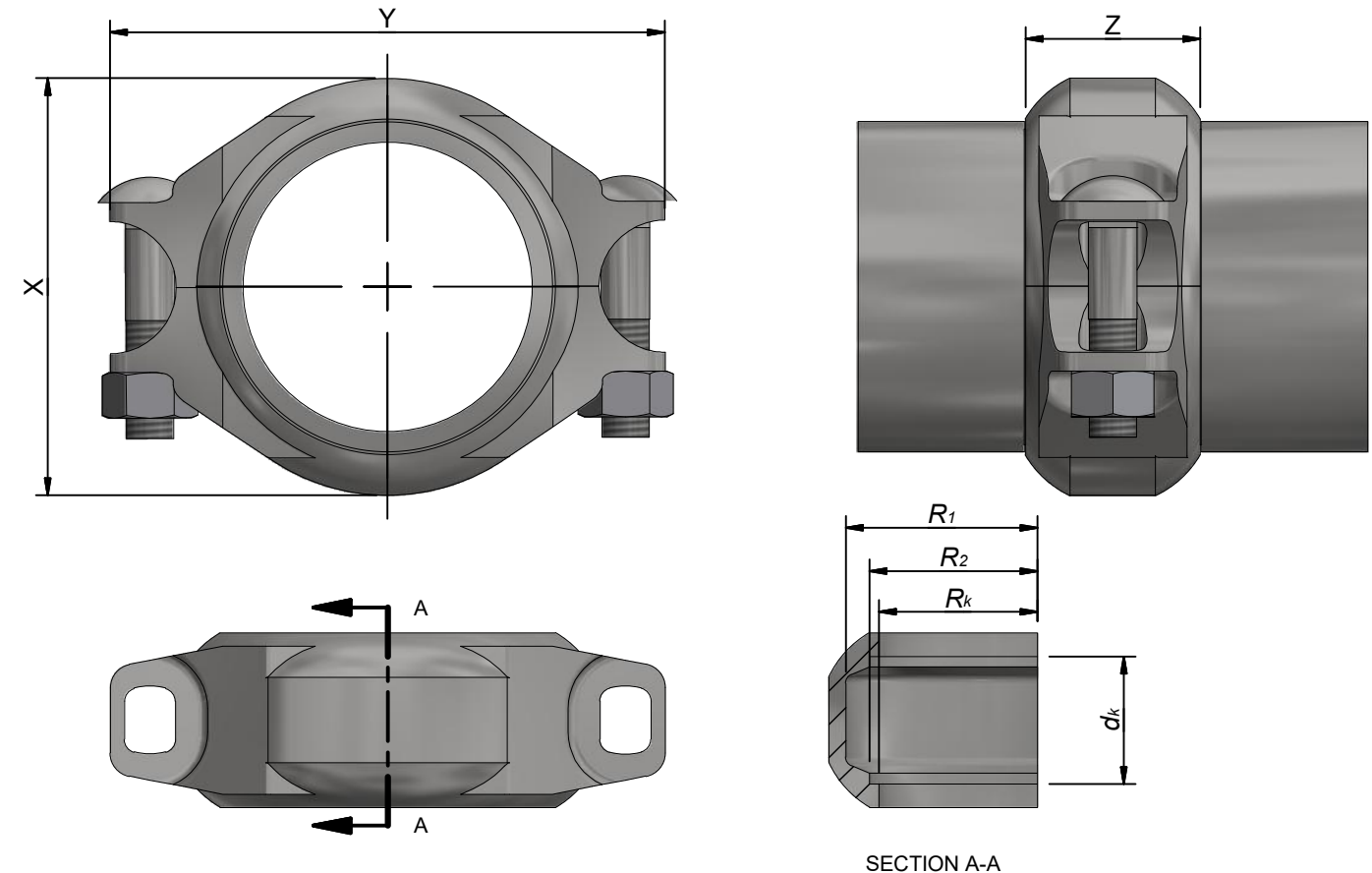

PRESSURE RATING:

NOMINAL SIZES	RATED PRESSURE	PROOF TEST PRESSURE
0.75" - 8"	600 PSI (41 BAR)	900 PSI (62 BAR)

DIMENSIONS:

NOMINAL SIZE	X	Y	Z	dk	R1	R2	Rk	APPROX. WT
INCH	INCH [MM]	INCH [MM]	INCH [MM]	INCH [MM]	INCH [MM]	INCH [MM]	INCH [MM]	LB [KG]
3/4	1.91 [48.5]	3.04 [77.2]	1.68 [42.7]	1.37 [34.8]	0.81 [20.5]	0.54 [13.6]	0.48 [12.1]	0.81 [0.37]
1	2.29 [58.2]	3.42 [86.9]	1.68 [42.7]	1.37 [34.8]	1.00 [25.4]	0.67 [16.9]	0.60 [15.2]	0.97 [0.44]
1-1/4	2.50 [63.5]	3.65 [92.7]	1.71 [43.4]	1.35 [34.3]	1.11 [28.2]	0.85 [21.6]	0.77 [19.6]	1.08 [0.49]
1-1/2	2.76 [70.1]	4.06 [130.1]	1.71 [43.4]	1.35 [34.3]	1.23 [31.2]	0.98 [24.9]	0.90 [22.7]	1.21 [0.55]
2	3.24 [82.3]	4.38 [111.3]	1.85 [47.0]	1.35 [34.3]	1.47 [37.3]	1.21 [30.7]	1.13 [28.7]	1.92 [0.87]
2-1/2	3.74 [95.0]	5.30 [134.6]	1.85 [47.0]	1.35 [34.3]	1.72 [43.7]	1.46 [37.0]	1.37 [34.7]	2.14 [0.97]
3	4.36 [110.7]	6.05 [153.7]	1.85 [47.0]	1.35 [34.3]	2.03 [51.6]	1.78 [45.2]	1.68 [42.7]	2.40 [1.09]
4	5.70 [144.8]	7.60 [193.0]	2.02 [51.3]	1.50 [38.1]	2.64 [67.1]	2.28 [57.9]	2.17 [55.2]	4.54 [2.06]
5	7.22 [183.4]	9.50 [241.3]	2.02 [51.3]	1.50 [38.1]	3.18 [80.8]	2.82 [71.5]	2.70 [68.7]	9.30 [4.23]
6	8.18 [207.8]	10.25 [260.4]	2.02 [51.3]	1.50 [38.1]	3.71 [94.2]	3.34 [84.8]	3.23 [82.1]	9.74 [4.42]
8	10.89 [276.6]	13.44 [341.5]	2.34 [60.7]	1.75 [44.5]	5.85 [148.5]	5.41 [137.5]	5.29 [134.3]	24.50 [11.10]



- NOTES:
- DIMENSIONS SHOWN IN THE DRAWING ARE INDICATIVE. FOR DETAILED INFORMATION ON GD&T, CONTACT PIEDMONT
 - COUPLING IS RATED FOR SCH. 40 PIPE (OR THICKER) WITH CUT GROOVES ONLY
 - HOUSING MATERIAL IS CF8M (316 STAINLESS STEEL), CONFORM TO ASTM A351/A351M-13
 - BOLTS ARE ROUND HEAD, SQUARE NECK, 316SS BOLTS, CONFORM TO ASME B18.5-2012
 - NUTS ARE HEAVY HEX 316SS, CONFORM TO ASME/ANSI 18.2.2-1987
 - GASKETS ARE EPDM RUBBER (FLUSH-FIT/C-SHAPE)

PROPRIETARY AND CONFIDENTIAL NOTE:
THE INFORMATION CONTAINED IN THIS DRAWING IS THE SOLE PROPERTY OF PIEDMONT PACIFIC. ANY REPRODUCTION IN PART OR AS A WHOLE WITHOUT THE WRITTEN PERMISSION OF PIEDMONT PACIFIC IS PROHIBITED.

REV	DATE	REVISION DESCRIPTION	DRAWN	CHKD	ENG	APPVD
1	15-09-2015	WEIGHT INFORMATION ARE ADDED. DIMENSIONS UPDATED	AH	CZZ	AH	AH
2	19-04-2016	WEIGHT INFORMATION ARE ADDED. DIMENSIONS UPDATED	AH	CZZ	AH	AH
3	18-07-2016	DIMENSIONS REVISED	AH	CZZ	AH	AH
4	02-11-2017	LAYOUT UPDATED	JF	CZZ		

UNLESS NOTED OTHERWISE
INTERPRETATION: ANSI Y14.5
TOLERANCES: ±0.02 (0.75 MM)
ANGLE: ±1°
HOLE SIZES: ±0.02 (0.75 MM)
HOLE CENTERS: ±0.02 (0.75 MM)
SURFACE FINISH ON PART: 125
SURFACE FINISH ON DRING: 32
DO NOT SCALE PRINTS

PIEDMONT PACIFIC
GROOVE END FLEXIBLE PIPE COUPLING

TITLE:				
STYLE B COUPLING ASSEMBLY				
SCALE:	UNIT:	DRAWING NO.	SHEET:	REVISION:
N/A	INCH [MM]	1.0	1.0	4

