

DWG REF	QTY	PART NUMBER	DESCRIPTION	MATERIAL
SHELL				
1	1	ORDER SECTION	SHELL	Filament Wound Epoxy/Glass composites - Head locking grooves integrally wound in place.
2	2	98024	F/C Port	CF3M #
3	2	96077	F/C Port Seal	Ethylene Propylene .
HEAD - NON CODED				
4	2	96668	Elliptical Head Assy.	Engineering Thermoplastic.
5	2	96000	Head Seal	Ethylene Propylene - O - Ring
HEAD INTERLOCK				
6	2	47336	Quik Release Spiral Ring	316 Stainless Steel.
VESSEL SUPPORT				
7	* 2	52169	Saddle	Engineering Thermoplastic.
8	* 2	45042	Strap Assy.	304 Stainless Steel-PVC Cushion.
9	4	46265	Strap screw.	5/16-18 UNC, 18-8 Stainless Steel.
ELEMENT INTERFACE				
10	2	A/R	Adapter	Engineering Thermoplastic.
11	2	52245	Adapter seal	Ethylene Propylene - O - Ring
12	4	A/R	PWT Seal	Ethylene Propylene - O - Ring
13	1	97014	Thrust Cone	Engineering Thermoplastic.
* 3 each furnished with length code 4,5,6,7 & 8.				

VIEW AT CENTER SUPPORT
 CENTER VESSEL ON 2 OR 3 SUPPORTS
 AT SPAN(S) *S* : 3 SUPPORTS REQUIRED
 FOR LENGTHS 4 AND OVER

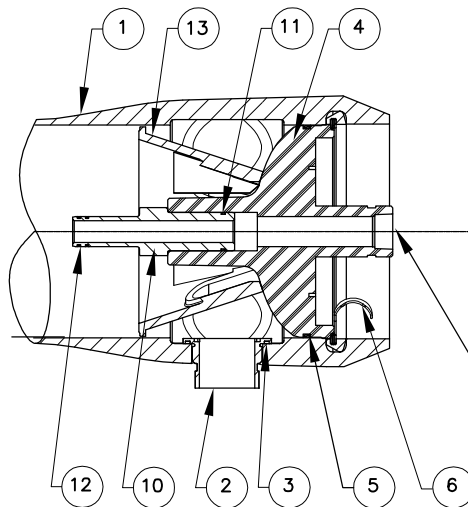

CAUTION: INCORRECT MANIFOLDING WILL CAUSE SEVERE LOCAL STRESS AROUND PORT AND MAY RESULT IN LEAKS AND PREMATURE FAILURE; TAKE EVERY PRECAUTION LISTED ON REVERSE. SEE INSTALLATION INSTRUCTIONS FOR FURTHER DETAILS

WARNING
 INTERNAL PORT PRESSURE NOT TO EXCEED 125 PSI.

SECTION THROUGH END CLOSURE

- NOTES:**
- MAX. ANGULAR VARIATION BETWEEN ANY PORTS $\pm 0.5^\circ$.
 - DIMENSION IN INCHES (MM APPROX.)
 - SHELL EXTERIOR COATED WITH WHITE, HIGH GLOSS POLYURETHANE PAINT.
 - NOT TO BE USED FOR CONSTRUCTION UNLESS CERTIFIED.
 - ITEM 13 DOWNSTREAM ONLY.
 - # GRADE CF3M AS PER ASME SA-351

Dash Length	L IN(MM)	P IN(MM)	S IN(MM)	Approx Weight LB(KG)
-1	59.15 (1502)	47 (1194)	23X1 (584)	46 (21)
-2	99.15 (2518)	87 (2210)	56X1 (1422)	55 (25)
-3	139.15 (3534)	127 (3226)	80X1 (2032)	64 (29)
-4	179.15 (4550)	167 (4242)	64X2 (1626)	73 (33)
-5	219.15 (5566)	207 (5258)	78X2 (1981)	82 (37)
-6	259.15 (6582)	247 (6274)	92X2 (2337)	90 (41)
-7	299.15 (7598)	287 (7290)	106X2 (2692)	99 (45)
-8	339.15 (8614)	327 (8306)	120X2 (3048)	108 (49)



PENTAIR
CODELINE® ECOLINE

DRAWN	KR	EcoLine 80-300 MEMBRANE HOUSING		
CHECKED	MD	DATE	DWG. NO.	REV. P.
		10APR15	99196	
APPROVED	SS	ECN	SCALE	SIZE
		3452	NONE	A3
		SHEET		1 OF 2

RATING:

DESIGN PRESSURE.....300 PSIG at 120°F
(2.068 MPa at 49°C)
MIN. OPERATING TEMP.....20°F
(-7°C)
FACTORY TEST PRESSURE.....CE / 1.1 TIMES
450 PSIG / 330 PSIG
(3.10 MPa) / (2.27 MPa)

QUALIFICATION PRESSURE..... 1200 PSI
(8.273 MPa)

INTENDED USE:

The EcoLine 80-300 Non Coded Fiberglass RO Pressure Vessel is designed for continuous, long term use as a housing for reverse osmosis membrane elements to desalt typical brackish waters at pressures up to 300 psi. Any make of eight-inch nominal diameter spiral-wound element is easily accommodated; the appropriate interfacing hardware for the element specified is furnished with the vessel.

The EcoLine 80-300 Non Coded vessel must be installed operated and maintained in accordance with the listed precautions and good industrial practice to assure safe operation over a long service life.

The high performance Filament wound FRP shell must be allowed to expand under pressure; undue restraint at support points or piping connections can cause leaks to develop in the shell. This side-ported vessel requires special precautions in mounting and connection to piping so that the vessel will not be subjected to excessive stress due to bending moments acting at the side openings in the fiberglass shell. The end closure, incorporating close fitting, interlocking metal components, must be kept dry and free of corrosion; deterioration can lead to catastrophic mechanical failure of the head.

Pentair will assist the purchaser in determining the suitability of this standard vessel for their specific operating conditions. The final determination however, including evaluation of the standard material of construction for compatibility with the specific corrosive environment, shall be the responsibility of the purchaser. Alternate materials with enhanced corrosion resistance are available on special order.

Specifications are subject to change without notice.

PRECAUTIONS:

- DO...read, understand and follow all instructions; failure to take every precaution will void warranty and may result in vessel failure
- DO...mount the shell on horizontal members at span "S" using compliant vessel supports furnished; tighten hold down straps just snug
- DO...align and center side ports with the manifold header. Correct, causes of misalignment in a row of vessels connected to the same header
- DO...use flexible type grooved-end pipe couplings, Victaulic® Style 77 or equal, at side ports; allow full, 0.125 inch gap between port and piping, and position piping to maximize flexibility of connection.
- DO...provide flexibility in, and support for piping manifolds so that vessel can grow in length under pressure without undue restraint; provide additional flexible joints in large pipes leading to manifold header.
- DO...provide overpressure protection for vessel set at not more than 105% of design pressure
- DO...inspect end closures regularly; replace components that have deteriorated and correct causes of corrosion.
- DO...Lubricate seals Sparingly, Using non petroleum based lubricants, i.e. parker Super 0-lube® Glycerin or suitable silicone based lubricants.
- DO NOT...work on any component until first verifying that pressure is relieved from vessel
- DO NOT...make rigid piping connections to ports or clamp vessel in any way that resists growth of fiberglass shell under pressure; ***ΔDIA = 0.015 in. (0.4mm) and ***ΔL = 0.2 in. (6mm) for a length code -8 vessel
- DO NOT...hang piping manifolds from ports or use vessel in any way to support other components
- DO NOT...tighten Permeate Port connection more than one turn past hand tight
- DO NOT... operate vessel without connecting both Permeate Ports internally to complete set of elements or otherwise plug ports internally so that external piping connection is not subjected to feed pressure
- DO NOT...install Spacer on downstream end of vessel
- DO NOT...operate vessel without Thrust Cone installed downstream
- DO NOT...pressurize vessel until double-checking to verify that the Locking Ring is in place and fully seated.
- DO NOT...operate vessel at pressure and temperature in excess of its rating.
- DO NOT...operate vessel with permeate pressure in excess of 125 psi at 120°F (0.86 MPa at 49°C).
- DO NOT...tolerate leaks or allow end closures to be routinely wetted in any way
- DO NOT...operate outside the pH range of 3-11.

ORDERING:

Using the chart below, please check the features you require and fax them with your purchase order to our customer service department for further processing. For optional materials and / or feature not listed below, please consult the factory for pricing and availability

VESSEL LENGTH CODE – please check one

MODEL EcoLine 80-300 Non Coded -1 -2 -3 -4 -5 -6 -7 -8

MEMBRANE BRAND AND MODEL – please check one and fill in information

- Please supply adapters for the following membrane brand and specific model
Brand _____ Model _____
- Membrane brand and model information is not currently available, but will be supplied to Pentair Water on or before the following date. ___ / ___ / ___

CERTIFICATION REQUIRED

- Standard, Certified by Pentair.
- CE Marked.

MATERIAL AND PORT CONFIGURATIONS OPTIONS – please check one

- Standard: all materials and port configurations as per drawing 99196 on the previous page
NOTE: The options listed below will increase the vessel price. Call factory for pricing details.

FEED PORT CONFIGURATION

- Standard – 1½” IPS pipe, grooved ends, with ports in-line. (1D5D).

Please fill out your feed port configuration in the space below.
List port location first, followed by port size for each choice.

PORT SIZE CODE	
D	1½” GROOVED END

- Serial number end
- Opposite end

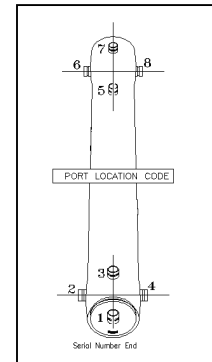

For complete information on proper use of the vessel
Please refer to the EcoLine Series, USER'S GUIDE_98244.

CODELINE BODY LABELS ARE PLACED AT 90° TO SERIAL NUMBER END AND AT 270° ON THE OPPOSITE SIDE END



Headquarter: 54/18 Bui Quang La, Ward 12, Go Vap District, HCMC, Vietnam
Office: 77 DHT10B, Dong Hung Thuan Ward, District 12, HCMC, Vietnam
Phone: (028) 6258 5368 – (028) 6291 9568
Email: info@atswatertechnology.com
Website: www.atswatertechnology.com