

ENGINEERING
TOMORROW

Danfoss

Data sheet

APP Pumps

APP 30 and APP 38 with Ceramics



ATS WATER
TECHNOLOGY



Table of Contents

1.	Introduction	3
2.	Naming structure	3
3.	Benefits	4
4.	Application examples	4
5.	Technical data	5
5.1	APP 30 and APP 38 with ceramics	5
6.	Flow at different rpm	6
6.1	APP 30 - APP 38 data curves [m ³ /h]	6
6.2	APP 30 - APP 38 data curves [GPM]	7
7.	Motor requirements	8
7.1	Calculation factor for APP 30 - APP 38	8
8.	Flushing valve curves	8
8.1	APP 30 – APP 38 integrated flushing valve	8
9.	Temperature and corrosion	9
9.1	Temperature	9
10.	Installation	9
10.1	Filtration	10
10.2	Noise	10
10.3	RO system with direct supply:	10
11.	Dimensions and connections	12
11.1	APP 38/1500	12
11.2	APP 30/1200	12
12.	Dimensions with motor unit	13
12.1	APP 30 and APP 38 with ceramics	13
13.	Accessories	14
13.1	Accessories for APP 30 and APP 38 with ceramics	14
14.	Service	14

1. Introduction

This data sheet is valid for APP pumps with Ceramics.

The Danfoss APP high-pressure pumps is designed according to EN 809 for use in applications with low viscosity and corrosive fluids such as:

- Sea water
- Brackish water
- Waste water

Danfoss APP pumps are positive displacement pumps with axial pistons that move a fixed amount of water in each cycle. Flow is proportional to the number of input shaft revolutions (rpm). Unlike centrifugal pumps, they produce the same flow at a given speed no matter what the discharge pressure.

Below sectional drawing is an example of an APP pump.

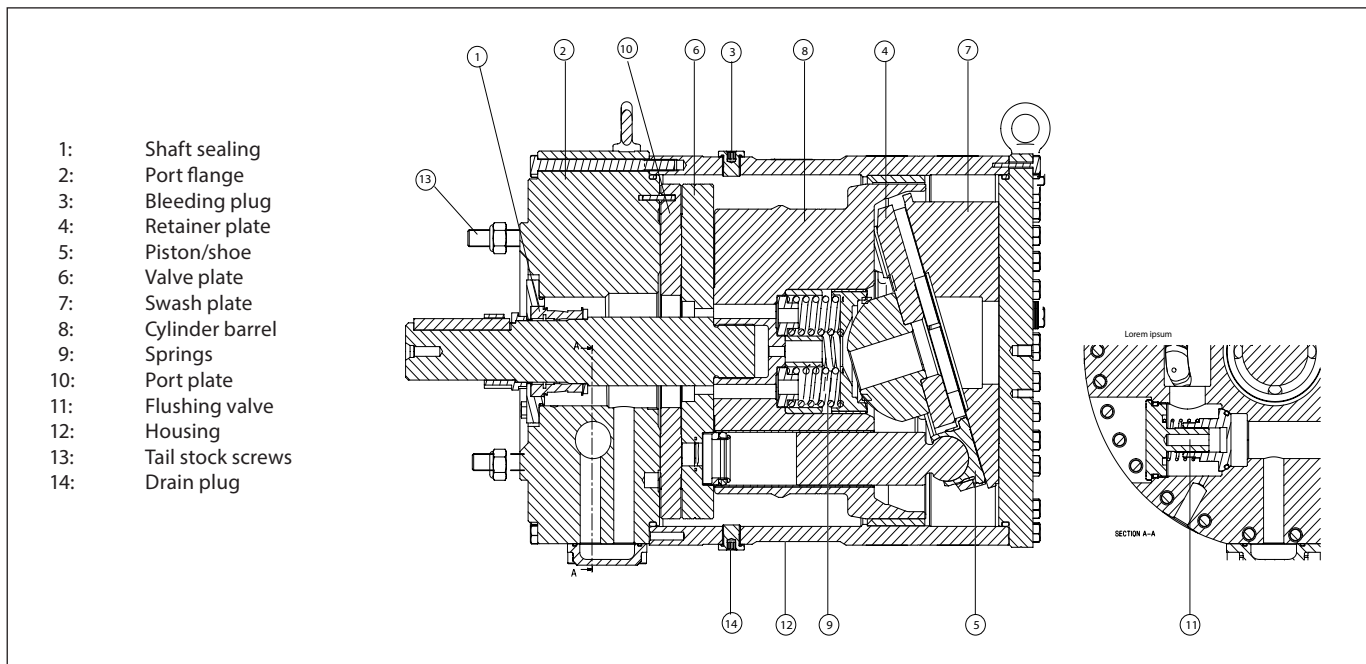

2. Naming structure

Design	Material Type	Capacity (m3/H)	RPM	Special/Certificates	Sealing materials	Pressure range	Robustness
APP	D: Duplex/Super Duplex steel	30	/1200	TC: 3.1 Test Certificate	C: NBR	1: 2-5 Bar Inlet @ 20-83 Bar Outlet	A: Level 1 (10µ ABS)
		38	/1500			2: 3-5 Bar Inlet @ 20-83 Bar Outlet	B: Level 2 (5µ Nom)
						6: 3-5 Bar Inlet @ 70-124 Bar Outlet	

Note: The naming structure is relevant for chapter 5.

PUMP

Type **APP D 30/1200 TC C1B**

Code No. **180B5007**

Serial No. **88364101-373**

MADE IN DENMARK

Danfoss A/S, 6430 Nordborg, Denmark

3. Benefits

- **Zero risk of lubricant contamination:**
 - Oil lubricants are replaced with the pumped medium, water, so there is no contamination risk from the pump.
- **Low maintenance costs:**
 - Efficient design and all-stainless steel construction ensure exceptionally long design life. Specific service intervals are available in the instruction 180R9446. Service is easy, and can be carried out on-site due to the simple design and few parts.
- **Low energy costs:**
 - The highly efficient axial piston design provides the lowest energy consumption of any comparable pump on the market.
- **Easy installation:**
 - The most compact and lightest design available.
 - The pump can be installed vertically and horizontally.
- **High reliability:**
 - No pulsation dampeners necessary due to extremely low pressure pulsation.
 - Powered directly by electric motors or combustion engines (with special coupling).
 - All pumps are supplied with an integrated flushing valve that allows the fluid to flow from inlet to the outlet, when the pump is not running.
- **High reliability:**
 - All parts are made of highly corrosion resistant materials e.g. Duplex (EN1.4462/ UNS S31803) and Super Duplex (EN1.4410/UNS S32750) stainless steel, carbon reinforced PEEK and ceramic.
- **Certified quality:**
 - IATF 16949, ISO 9001, ISO 14001.
 - Positive Material Identification (PMI) report available on request if ordered with the pump.

4. Application examples

- Danfoss APP pumps are built into a broad range of RO desalination plants around the world:
- Containerized solutions for hotels, resorts and residences on islands and in coastal regions
 - Mobile systems for humanitarian and military organizations
 - Onboard systems for ships and yachts
 - Offshore platforms for the oil and gas industry
 - Municipal and regional waterworks

5. Technical data

5.1 APP 30 and APP 38 with ceramics

Pump		APP D 30/1200 TC C1B	APP D 38/1500 TC C 2B
Code number APP pumps with ceramics		180B5007	180B5008
Geometric displacement	cm ³ /rev.	444	444
	in ³ /rev.	27.09	27.09
Pressure			
Max. outlet ¹⁾ pressure continuous	barg	83	83
	psig	1200	1200
Min. outlet ¹⁾ pressure	barg	20	20
	psig	290	290
Inlet pressure continuous	barg	2 - 5	2* - 5
	psig	29 - 72.5	29 - 72.5
Max. inlet pressure peak	barg	10	10
	psig	145	145
Speed			
Min. speed continuous	rpm	700	700
Max. speed continuous	rpm	1200	1500
Typical flow - Flow curves available in section 6			
1000 rpm at max. pressure	m ³ /h	26.0	26.2
1500 rpm at max. pressure	m ³ /h		39.3
1200 rpm at max. pressure	GPM	137.6	138.4
Technical specifications			
Media ²⁾ temperature	°C	2 - 50	2 - 50
	°F	35.6 - 122	35.6 - 122
Ambient temperature	°C	0 - 50	0 - 50
	°F	32 - 122	32 - 122
Weight (dry)	kg	105	105
	lb	231	231
Sound pressure level ⁴⁾	dB(A)	85	85
Footprint with IEC motor ⁵⁾	m ²	0.83	0.83
	foot ²	8.93	8.93
Typical motor size			
Max. speed at max. pressure	kW	90.0	110
1200 rpm at max. pressure	HP	125.0	
Torque at max. outlet pressure	Nm	608	617
	lbf-ft	449	455

* When operating at rpm above 1200 rpm the min inlet pressure must be more than 3 barg (43.5 psig)

¹⁾ For lower and higher pressure, please contact Danfoss.

²⁾ Dependent on the NaCl concentration - see chapter 8.

⁴⁾ Category 2, Zone 1 or Category 3, Zone 2.

⁴⁾ A-weighted sound pressure level at 1 m from the pump unit surfaces (reference box) acc. to EN ISO 20361 section 6.2. The noise measurements are performed acc. to EN ISO 3744:2010 on a motor-pump unit at max. pressure and speed.

⁵⁾ Max. area covered with recommended motor configuration (excl. of space to service pump)

6. Flow at different rpm

If the flow required and the rotation speed (rpm) of the pump is known, it is easy to select the pump fitting the application best by using the diagrams below.

Furthermore, these diagrams shows that the flow can be changed by changing the rotation speed of the pump.

The Flow/Rpm ratio is considered proportional. The Total efficiency is displayed at different ΔP . The total efficiency is relative constant within normal RO pressure variations. The total efficiency can be found in the top of the diagram.

The vertical blue lines indicate where the pump can operate continuously. The required inlet pressure is increasing when the speed changes. The pump power consumption is indicated in the ΔP graph but can also be calculated by using the factors in section 5.2

6.1 Data curves for APP 30 and APP 38 with ceramics [m³/h]

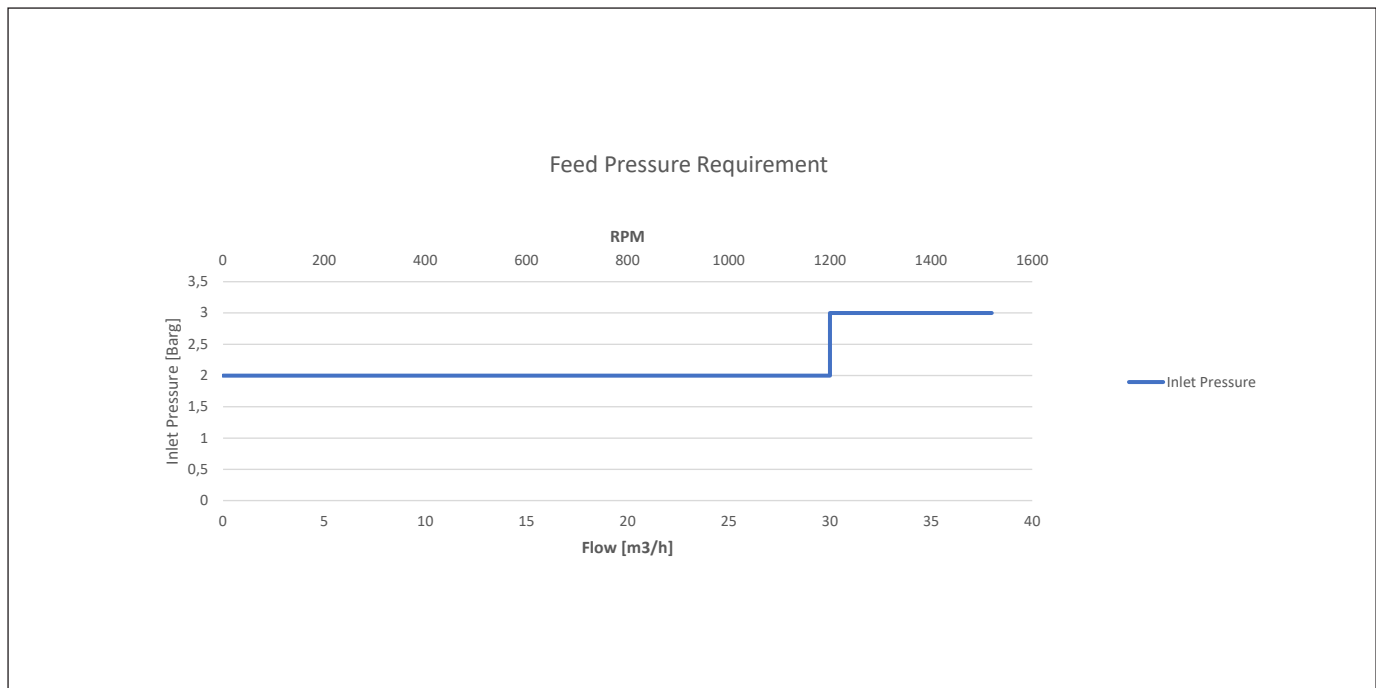
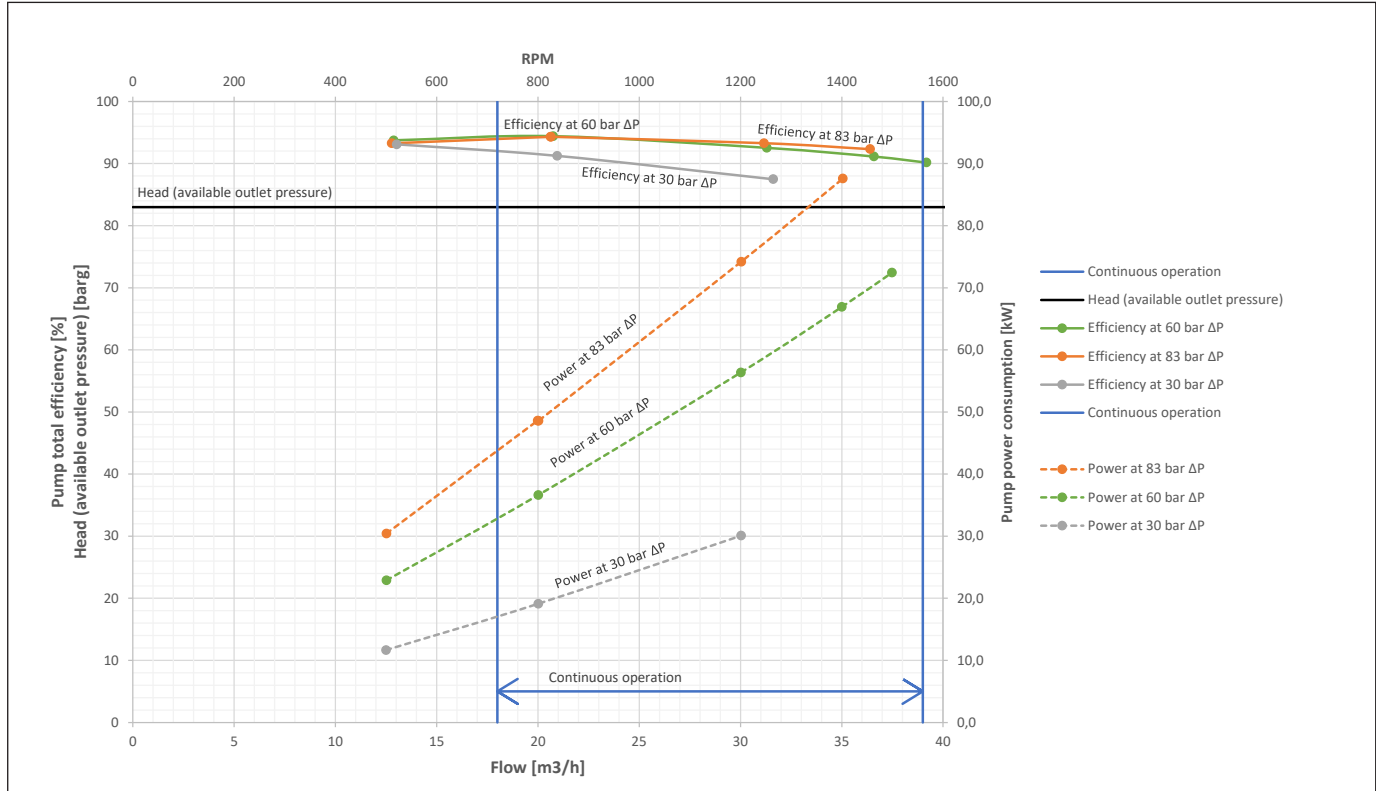

6.2 Data curves for APP 30 and APP 38 with ceramics [GPM]

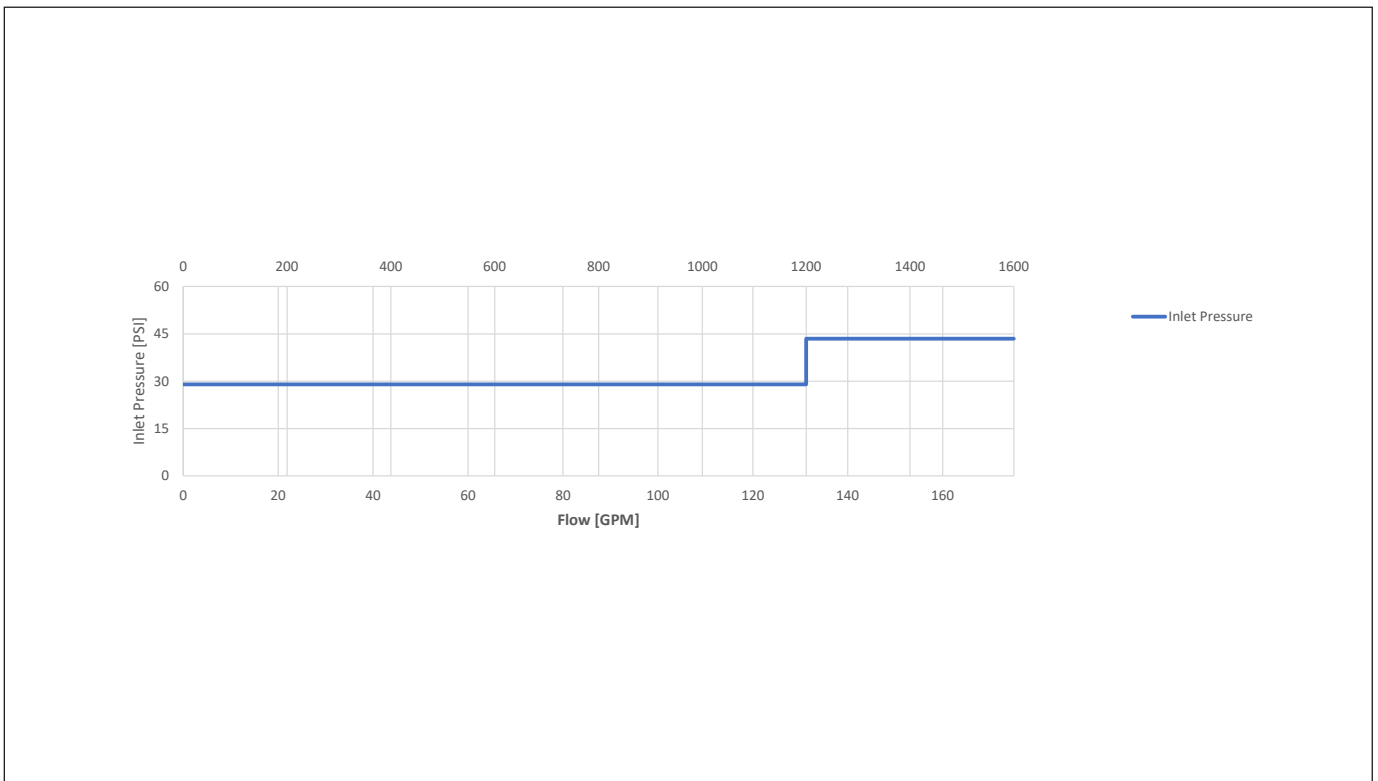
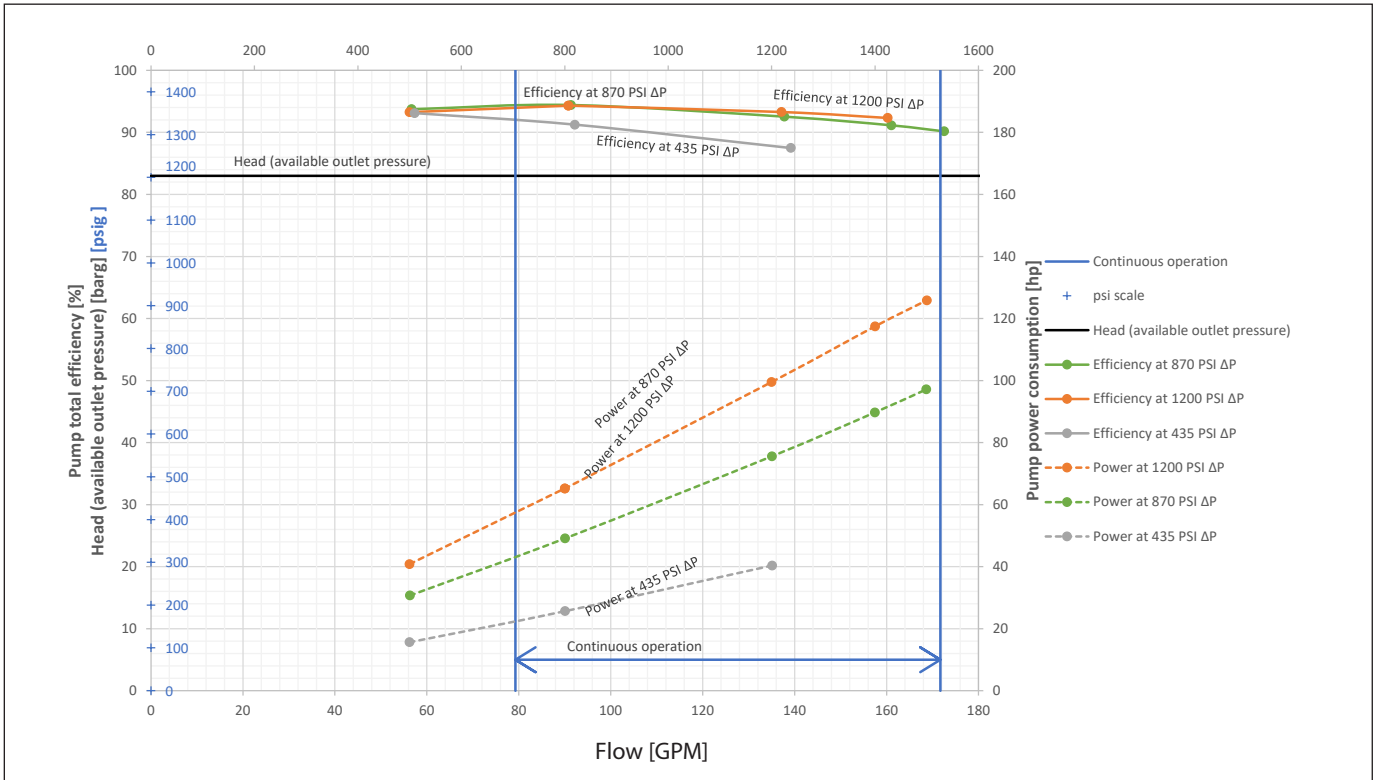

7. Motor requirements

The power requirements and torque can be determined using one of the following guiding equations to ensure correct motor selection both:

$$\text{Required power} = \frac{\text{l/min} \times \text{barg}}{\text{Calc. factor}} \text{ [kW]} \text{ or } \frac{16.7 \times \text{m}^3/\text{h} \times \text{barg}}{\text{Calc. factor}} \text{ [kW]} \text{ or } \frac{0.35 \times \text{GPM} \times \text{psig}}{\text{Calc. factor}} \text{ [hp]}$$

$$\text{Required torque} = \frac{\text{l/min} \times \text{barg}}{\text{Calc. factor}} \text{ [Nm]} \text{ or } \frac{16.7 \times \text{barg}}{\text{Calc. factor}} \text{ [Nm]} \text{ or } \frac{0.35 \times \text{GPM} \times \text{psig}}{\text{Calc. factor}} \text{ [hp]}$$

Name	rpm	Calculation factor
APP x 30	1200	50.24
APP x 38	1500	53.38

1 hp	=	0.75 kW
1 GPM	=	3.79 l/min
1 m ³ /h	=	4.40 GPM
1 kW	=	1.34 hp
1 l/min	=	0.26 GPM
1 GPM	=	0.23 m ³ /h

8. Flushing valve curves

All pumps are supplied with an integrated flushing valve that allows the fluid to flow from inlet to the outlet, when the pump is not running.

8.1 APP 30 – APP 38 integrated flushing valve

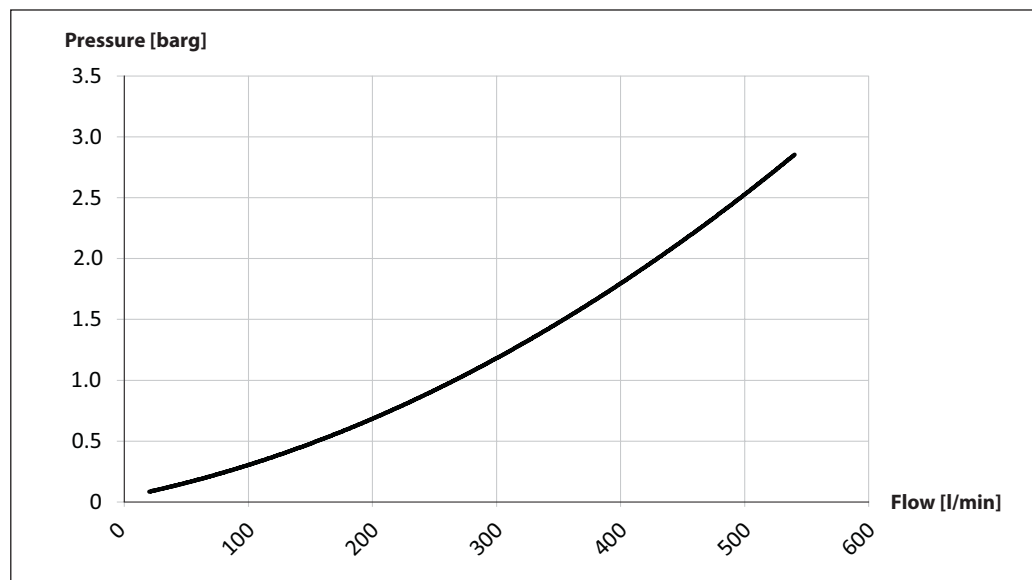

9. Temperature and corrosion

9.1 Temperature

Fluid temperature: Min. +2°C to max. +50°C (Min. +35.6°F to max. +122°F)
Ambient temperature: Min. +2°C to max. +50°C (Min. +35.6°F to max. +122°F)

In case of lower operating temperatures, please contact Danfoss High Pressure Pumps. The chart below illustrates the corrosive resistance of different types of stainless steel related to NaCl concentration and temperature.

If the water pump is operated above the Duplex line, always flush the water pump with fresh water at all operation stops in order to minimize the risk of crevice corrosion.

In case the pump is stopped for more than one day it should always be flushed with fresh water as described in section 13.

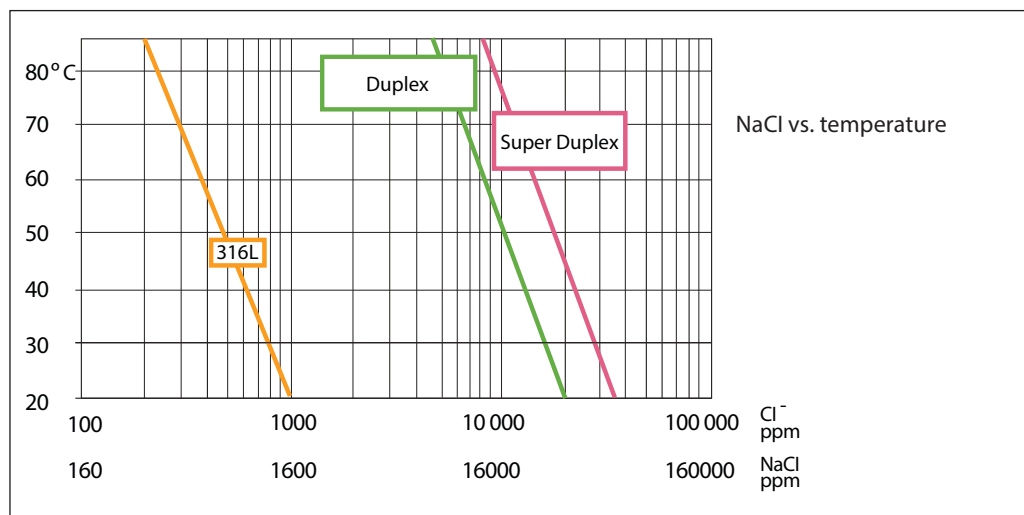

10. Installation

Below drawing shows how the pump is installed to an electric motor. Alignment of the pump and motor shafts is controlled by the mount. This also protects the pump shaft against any axial or radial loads.

During transportation the shaft protection cap must be mounted. Before installing the coupling the cap must be removed.

If alternative mounting is required, please contact your Danfoss sales representative for further information.

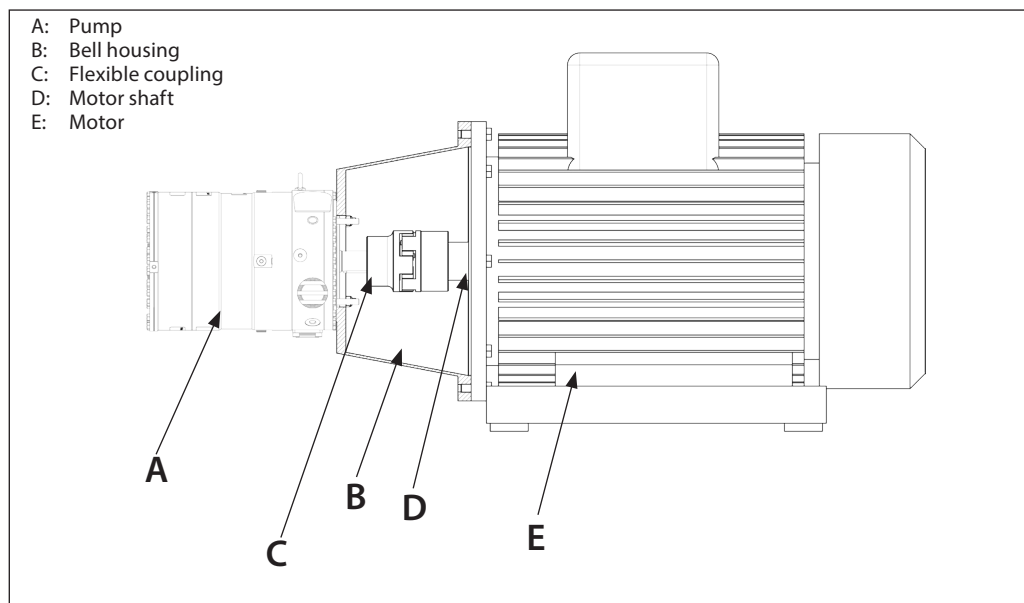

10.1 Filtration

Proper filtration is crucial for the performance, maintenance and warranty of your pump.

Protect your pump, and the application in which it is installed in by always ensuring that all filtration specifications are met, and by always changing filter cartridges according to schedule.

High quality water extends the service life of the whole system.

Water to the APP pumps with ceramics must be filtered to 5 µm nominal, using melt-blown depth filter with a proven efficiency of min. 85%. Consult Danfoss for correct choice of filter.

It is important when selecting the filter and filter housing to ensure good cartridge end sealings. As the various filters on the market differ greatly, Danfoss High Pressure Pumps recommends using cartridges with consistent, reliable performance and high efficiency and where fibres are blown continuously onto a central support core. Danfoss High Pressure Pumps does not recommend cartridges requiring any type of binders or resins.

For more information on the importance of proper filtration, including explanation of filtration principles, definitions and guidance on how to select the right filter for your pump, please consult our Filtration information and specifications (Danfoss document number AI317041322125en-000201).

10.2 Noise

Vibrations from the pump can be transferred to the system components that are attached to the pump. To minimize vibrations and noise throughout the system, it is therefore very important to mount the pump unit correctly on a frame with anti-vibration-dampeners, and to use flexible hoses rather than metal pipes where possible.

The noise level is influenced by:

- **Pump speed:**
High rpm generates more fluid/structure borne pulsations/vibrations than low rpm.
- **Discharge pressure:**
High pressure generates more noise than low pressure.
- **Pump mounting:**
Rigid mounting generates more noise than flexible mounting, because of structure-borne vibrations. Be sure to use dampers when mounting.
- **Connections to pump:**
Pipes connected directly to the pump make more noise than flexible hoses, because of structure-borne vibrations.
- **Variable frequency drives (VFD):**
Motors regulated by VFDs can produce more noise if the VFD does not have the right settings.

10.3 RO system with direct supply:

Inlet line:

- a) Dimension the inlet line to obtain minimum pressure loss (large flow area, minimum pipe length, minimum number of bends/connections, and fittings with low or no pressure losses). If relevant, please consult "Parallel coupled pumps and iSaves" (180R9354)

Inlet filter:

- b) Install an inlet filter (1) in front of the APP pump (2). Please consult section 9.1, "Filtration" for guidance on how to select the right filter. Thoroughly clean pipes and flush system prior to start-up.

Low pressure relief valve:

- c) Install a low pressure relief valve (9) in order to avoid system or pump damage in case the system stops abruptly, for instance due to a power outage, or if the pump is spinning backwards.

Hoses:

- d) Use flexible hoses (4) to minimize vibrations and noise. Please consult the Danfoss Hoses and hose fittings data sheet (AI319454706473en-000201) for guidance.

Inlet pressure:

- e) In order to eliminate the risk of cavitation and other pump damage, pump inlet pressure must always be maintained according to specifications described in section 4 about technical data. Install a monitoring pressure switch (3) between the filter (1) and the pump inlet. Set the minimum inlet pressure according to specifications described in section 4 about technical data. If the inlet pressure is lower than the minimum pressure set, the monitoring pressure switch must prevent the pump from starting or from running.

Flushing valve:

- f) For easy system filling and flushing, an integrated flushing valve (6) is in the APP pump.

Non-return valve:

- g) A non-return valve (7) in outlet can be installed in order to avoid backspin of the pump. The volume of water in the membrane vessel works as an accumulator and will send flow backwards in case of the pump stops abruptly.

High pressure safety or relief valve:

- i) As the Danfoss APP pump begins to create pressure and flow immediately after start-up and regardless of any counter pressure, a safety or pressure relief valve (8) should be installed after the non-return valve to prevent system damage and to avoid high pressure peaks.

Note: If a non-return valve is mounted in the inlet line, a low-pressure relief valve is also required between the non-return valve and the pump as protection against high-pressure peaks.

Preferred design - see section 10.3

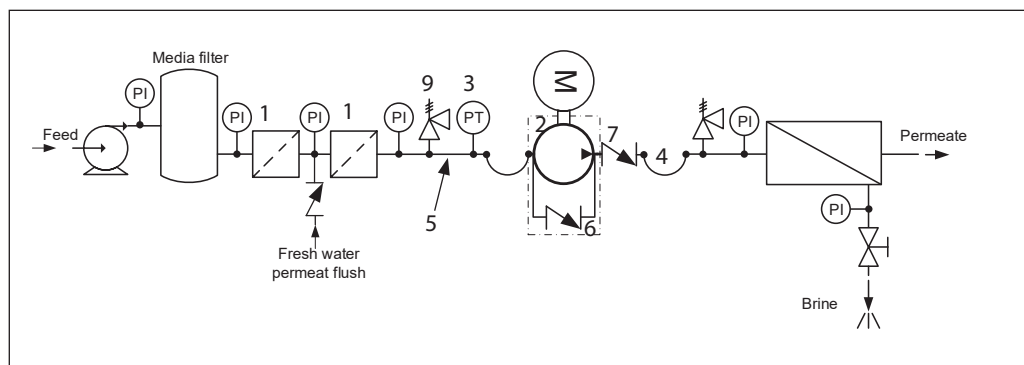

11. Dimensions and connections

11.1 APP 30 and APP 38 with ceramics

Accessories see section 12. For more details on the accessories, please contact the Danfoss High Pressure Pumps sales organisation.

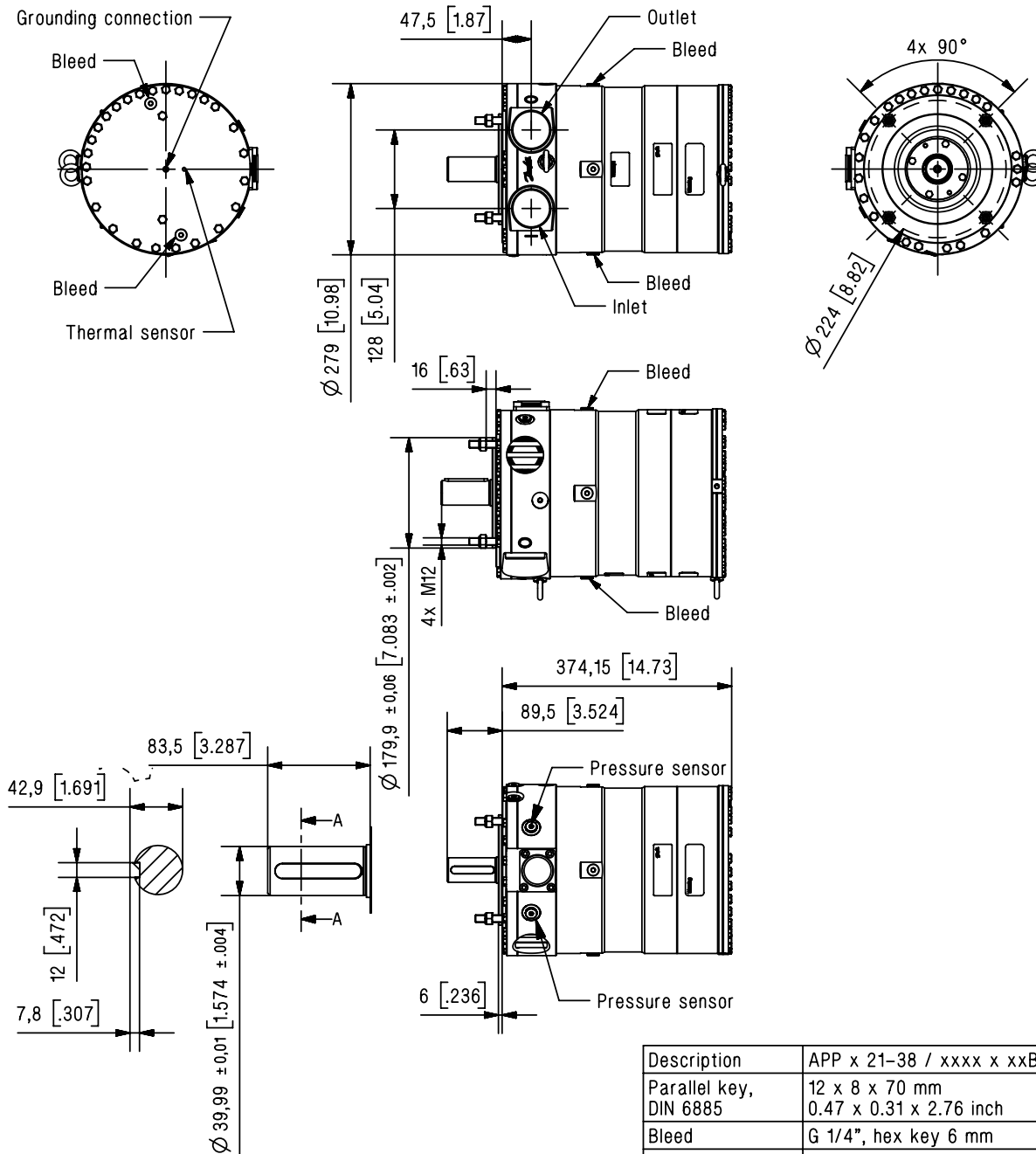

Dimensions without tolerances acc. To ISO 2768-1 designation C.

Description	APP x 21-38 / xxxx x xxB
Parallel key, DIN 6885	12 x 8 x 70 mm 0.47 x 0.31 x 2.76 inch
Bleed	G 1/4", hex key 6 mm
Inlet port	M60x1.5; depth 23 mm
Outlet port	M60x1.5; depth 23 mm
Earth connection	M8, depth 11 mm
Thermal sensor	M6, depth 11 mm
Pressure sensor	G 1/4", hex key 6 mm

12. Dimensions with motor unit

12.1 APP 30 and APP 38 with ceramics

The examples of assemblies with motor are only for IEC motors and couplings. Please make sure to check required motor power and dimensions when selecting size of pump and motor. For advice and calculation tool, please contact Danfoss.

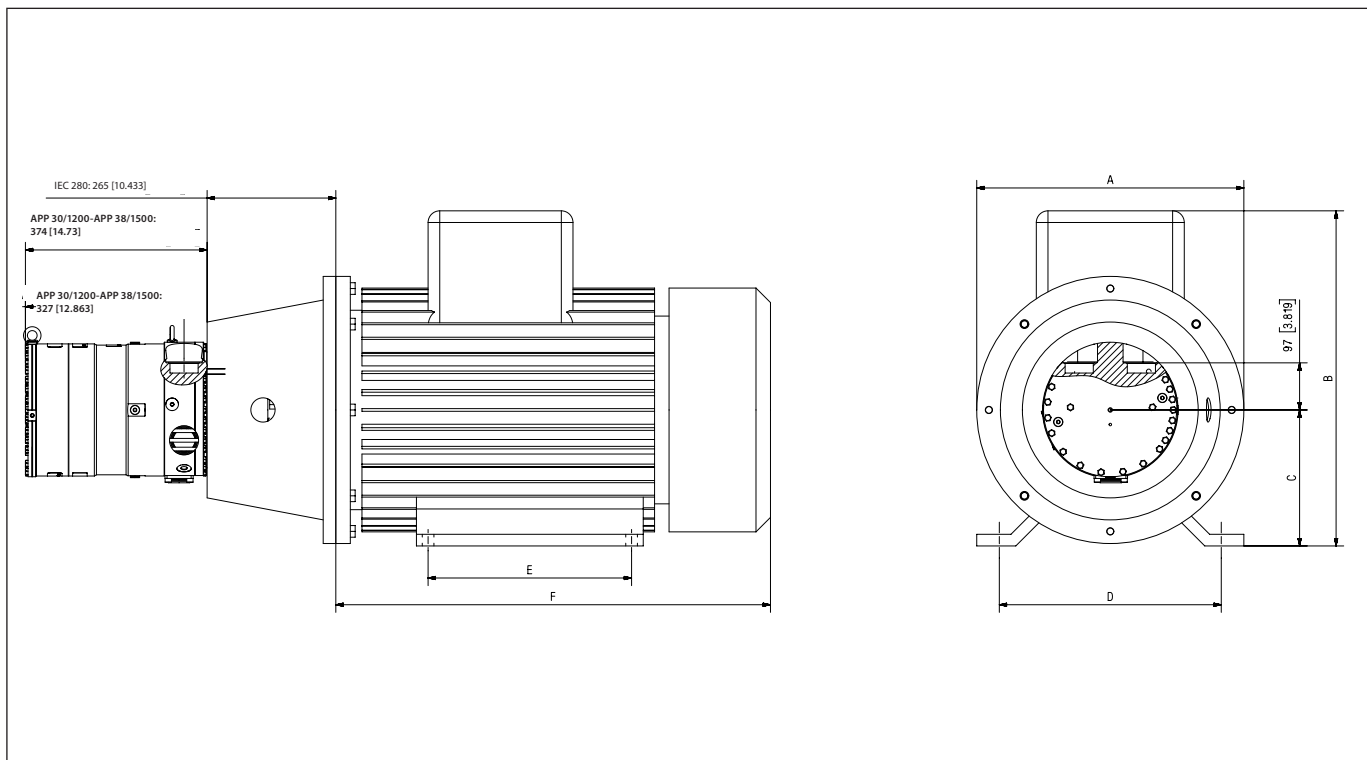

Pump	A mm (inch)	B mm (inch)	C mm (inch)	D mm (inch)	E mm (inch)	F mm (inch)	IEC Electric motor
APP 30 - 38 with ceramics	550 (21.65)	693 (27.28)	280 (11.02)	457 (17.99)	419 (16.50)	895 (35.24)	90 kW, IEC 280 M-4



13. Accessories

13.1 Accessories for APP x 30–38 with ceramics

Accessories	Type	Code No.
3" inlet hose kit - 2m (79")	3" Victaulic	180Z0144
2" outlet hose APP 30-38	1.78m (70") 1m (39.4")	2 1/2" Victaulic
		180Z0280
3" inlet connector APP 30-38	M60 - 3" Victaulic	180B3208
Non-return valve (outlet) Super Duplex APP 30-38	M60 - 2 1/2" Victaulic	180H0059

14. Service

Danfoss APP pumps are designed for long operation, low maintenance and reduced lifecycle costs.

Provided that the pump has been running according to the Danfoss specifications, Danfoss recommends 16.000 hours service interval, but as the guarantee is 8000 Hours service-free operation or max. 18 month from date of production it is recommended to perform an inspection before the end of the warranty period to ensure that any potential issues are identified and can be resolved promptly through the warranty claims process

If Danfoss recommendations concerning system-design are not followed, it will strongly influence the life of the APP pumps. Other factors that affect pump performance and lifetime include:

- Running the pump at speed outside specifications.
- Supplying the pump with water at temperature higher than recommended.
- Running the pump at inlet pressure outside specifications.
- Running the pump at outlet pressure outside the specifications.
- Wrong rotation of the shaft
- Insufficient bleeding of the pump
- Filtration not meetin specifications

If the recommendations in the manual are not followed, Danfoss reserves the right to void the warranty.

Maintenance

Periodic inspections are required to ensure worn parts (if any), are replaced in due time. Operational conditions such as water quality should be taken into consideration when determining the frequency of the inspections.

Pump shutdown:

The APP pumps are made of Duplex/Super Duplex materials with excellent corrosion properties. It is, however, always recommended to flush the pump with freshwater when the system is shut down.

When stopping the pump for more than 1 day flush the pump with permeate by rotating the pump for 10 sec. Flushing through the flushing valve of the pump without rotating the pump is not enough for cleaning the inside of the pump. The pump can be flushed with biocide like the membranes. The biocide must be compatible with the materials used in the pump.

Repair assistance

In case of irregular function of the APP pump, please contact Danfoss High Pressure Pumps.



Headquarter: 54/18 Bui Quang La, Ward 12, Go Vap District, HCMC, Vietnam
Office: 77 DHT10B, Dong Hung Thuan Ward, District 12, HCMC, Vietnam
Phone: (028) 6258 5368 – (028) 6291 9568
Email: info@atswatertechnology.com
Website: www.atswatertechnology.com

Danfoss A/S

High Pressure Pumps • danfoss.com • +45 7488 2222 • highpressurepumps@danfoss.com

Any information, including, but not limited to information on selection of product, its application or use, product design, weight, dimensions, capacity or any other technical data in product manuals, catalogues descriptions, advertisements, etc. and whether made available in writing, orally, electronically, online or via download, shall be considered informative, and is only binding if and to the extent, explicit reference is made in a quotation or order confirmation. Danfoss cannot accept any responsibility for possible errors in catalogues, brochures, videos and other material. Danfoss reserves the right to alter its products without notice. This also applies to products ordered but not delivered provided that such alterations can be made without changes to form, fit or function of the product.
 All trademarks in this material are property of Danfoss A/S or Danfoss group companies. Danfoss and the Danfoss logo are trademarks of Danfoss A/S. All rights reserved.